



AW MILLER
TECHNICAL SALES, INC.

EAST AURORA, NY
716.652.8282

HARMONY, PA
724.453.1690

STE-LAURENT, QC
514.333.9174

HARLEYSVILLE, PA
215.256.8281

Mazak

HCN-Q

SERIES

[12500Q / 12500QS / 16000Q / 16000QS / 16800Q / 16800QS]



High productivity for large workpieces

Large horizontal machining center series with spindle quill

- Deep boring of large workpieces
- Rigid machine construction for heavy-duty machining
- Designed for high-speed and high-accuracy performance



HCN-1600QS shown with optional equipment

Horizontal machining center with quill

HCN-Q SERIES

Max. workpiece size

- Φ3000 mm (Φ118.11") Height: 2400 mm (94.49") (HCN-16800Q, 16800QS)
- Φ3000 mm (Φ118.11") Height: 2000 mm (78.74") (HCN-16000Q, 16000QS)
- Φ2350 mm (Φ92.52") Height: 1800 mm (70.87") (HCN-12500Q, 12500QS)

Spindle quill for deep boring

W-axis stroke: 550 mm (21.65")

Integral spindle/motor

Max. output: 45 kW [40% ED (30 min. rating)]

Single table and 2-pallet changer versions available

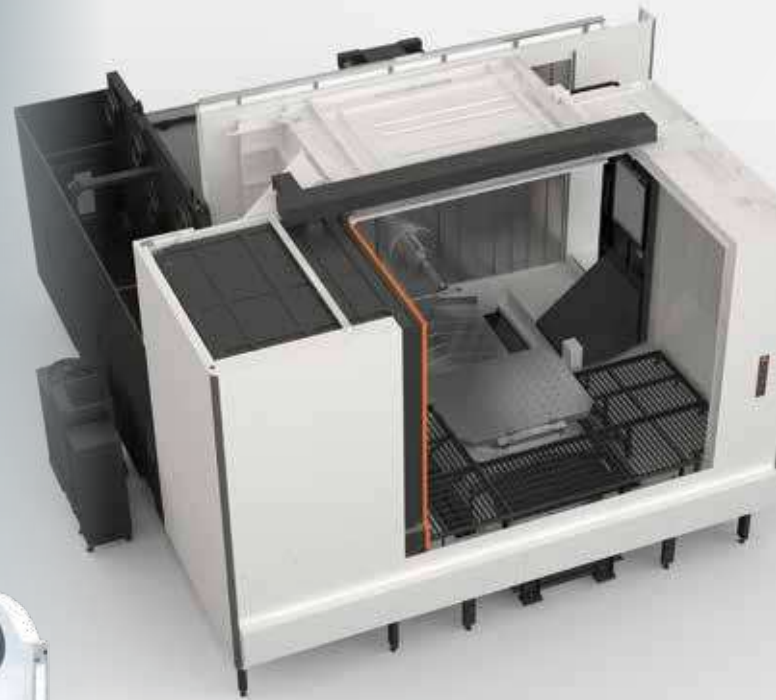

Example workpieces



Valve box for fracturing pump

Body for machining center



Gear housing for wind generator



HCN-Q series specifications

		HCN-12500Q (2-pallet changer)	HCN-12500QS (single table)	HCN-16000Q (2-pallet changer)	HCN-16000QS (single table)	HCN-16800Q (2-pallet changer)	HCN-16800QS (single table)
Pallet	Pallet size	1250 mm × 1000 mm (49.21" × 39.37")		1600 mm × 1250 mm (62.99" × 49.21")			
Stroke	X axis (column right/left)	2030 mm (79.92")		2800 mm (110.24")			
	Y axis (spindle up/down)	1400 mm (55.12")		1600 mm (62.99")		2000 mm (78.74")	
	Z axis (table back/forth)	1525 mm (60.04")		1850 mm (72.83")			
	W axis (quill back/forth)	550 mm (21.65")					
Capacity	Max. workpiece dimensions	Φ2350 mm × 1800 mm (Φ79.92" × 70.87")		Φ3000 mm × 2000 mm (Φ118.11" × 78.74")		Φ3000 mm × 2400 mm (Φ118.11" × 94.49")	
Table load capacity		5000 kg (11023 lbs)		8000 kg (17637 lbs)	10000 kg (22046 lbs)	8000 kg (17637 lbs)	10000 kg (22046 lbs)

Higher Accuracy, Higher Productivity

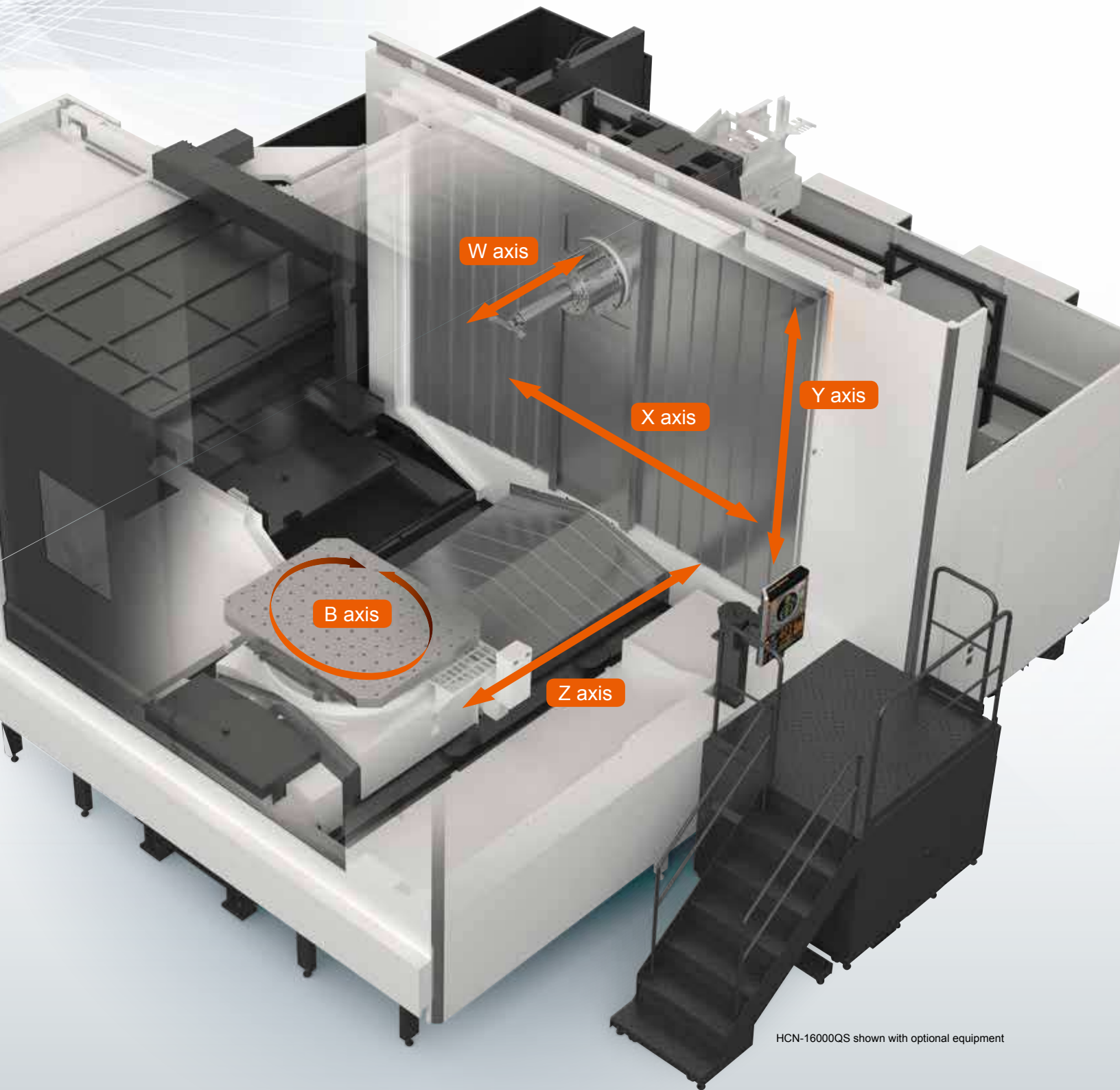

HCN-16000QS shown with optional equipment

High-accuracy machining of large workpieces

Spindle

Integral spindle/motor

Thanks to the integral spindle/motor design, vibration is minimized during high-speed operation to ensure exceptional surface finishes and maximum tool life.

Spindle temperature control

For high-accuracy machining, temperature-controlled cooling oil is circulated around the spindle bearings and headstock to minimize any thermal change to the spindle.

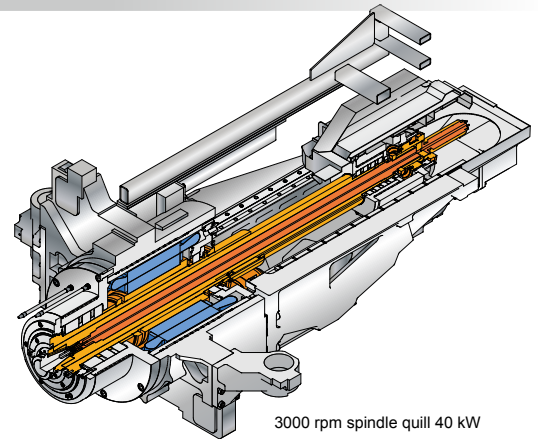

X, Y, Z, W axes

Y-axis twin ball screw

The spindle headstock is driven by two ball screws in the Y axis for minimum vibration to ensure accuracy and stability during high-speed machining.

Linear roller guides utilized on the X, Y, Z axes

Linear roller guides on the X, Y and Z axes are utilized by the HCN-Q series in order to provide high-accuracy and heavy-duty machining.

Ball screw core cooling

Temperature-controlled cooling oil circulates through the ball screw cores to ensure stable machining accuracy over extended periods of high-speed operation.



Table

Roller gear cam

The NC rotary table uses a roller gear cam system for 0.0001° positioning increments and high-accuracy performance.

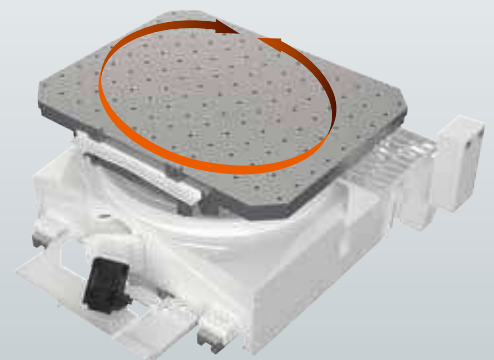

Higher Productivity



Advanced integral spindle/motor for high productivity

- Spindle bearings I.D.: $\Phi 180$ mm ($\Phi 7.09$ "
The multiple-row front spindle bearings provide the rigidity required for heavy-duty machining.
- Quill I.D.: $\Phi 130$ mm ($\Phi 5.12$ "
with spindle/quill cooling **OPTION**
- High-output, high-torque gearless integral spindle/motor – standard equipment

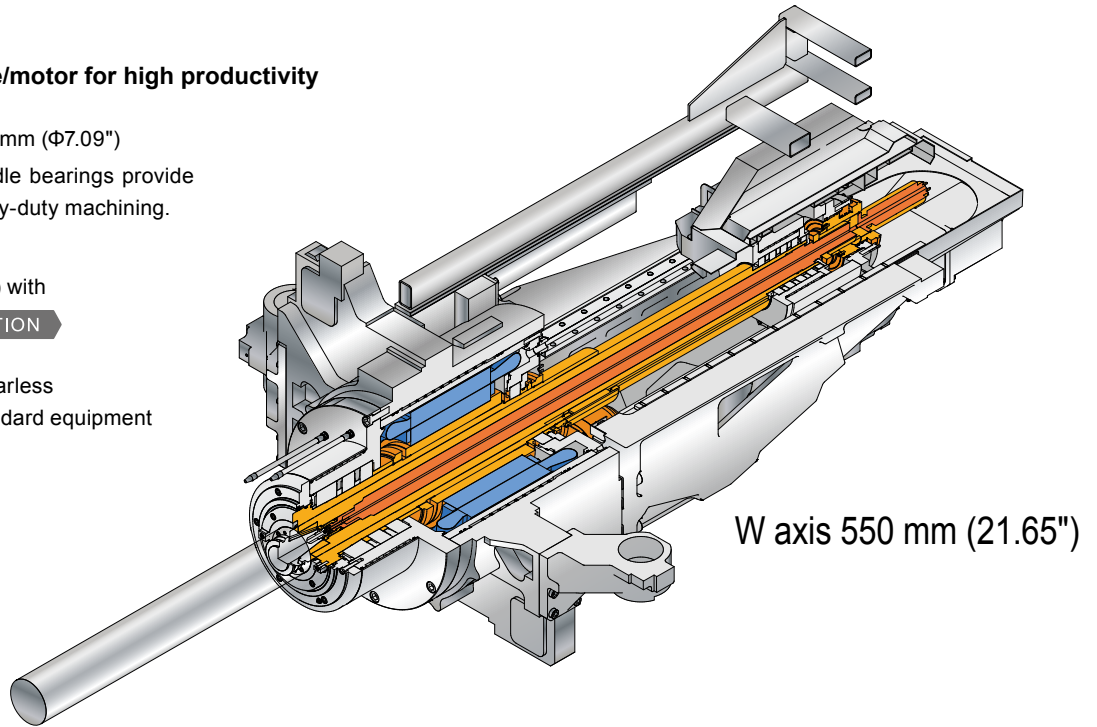

3000 rpm Spindle quill

Speed	3000 rpm
Output	AC 45 kW (60 HP) [40% ED (30 min. rating)]
	AC 37 kW (50 HP) cont. rating
Torque	1849 N.m (188.4 kgf.m) [40% ED (30 min. rating)]

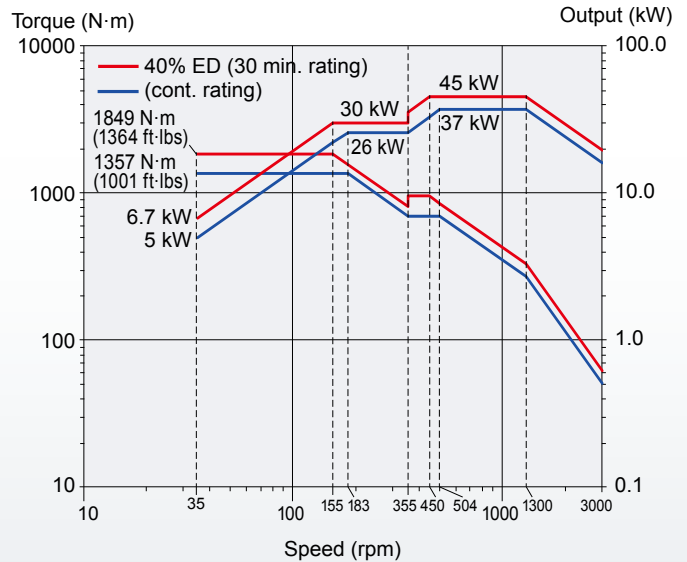

Machining example [Material: S45C W axis: no extension]

Face mill MRR 1492 cc/min		End mill MRR 1056 cc/min		Large diameter drill MRR 900 cc/min	
Tool	$\Phi 200$ mm ($\Phi 7.87$ " face mill	Tool	$\Phi 66$ mm ($\Phi 2.6$ " steel end mill	Tool	$\Phi 150$ mm ($\Phi 5.91$ " drill
Spindle speed	398 rpm	Spindle speed	1230 rpm	Spindle speed	255 rpm
Cutting width	150 mm (5.91")	Cutting width	53 mm (2.09")		
Depth of cut	5 mm (0.2")	Depth of cut	30 mm (1.18")		

Note: machining capability varies by W-axis (quill) position
Above data for reference only.

Higher Productivity

Tool attachments **OPTION** for HCN-12500Q, 16000Q, 16800Q

Tool attachments can be automatically mounted on the spindle for increased versatility.

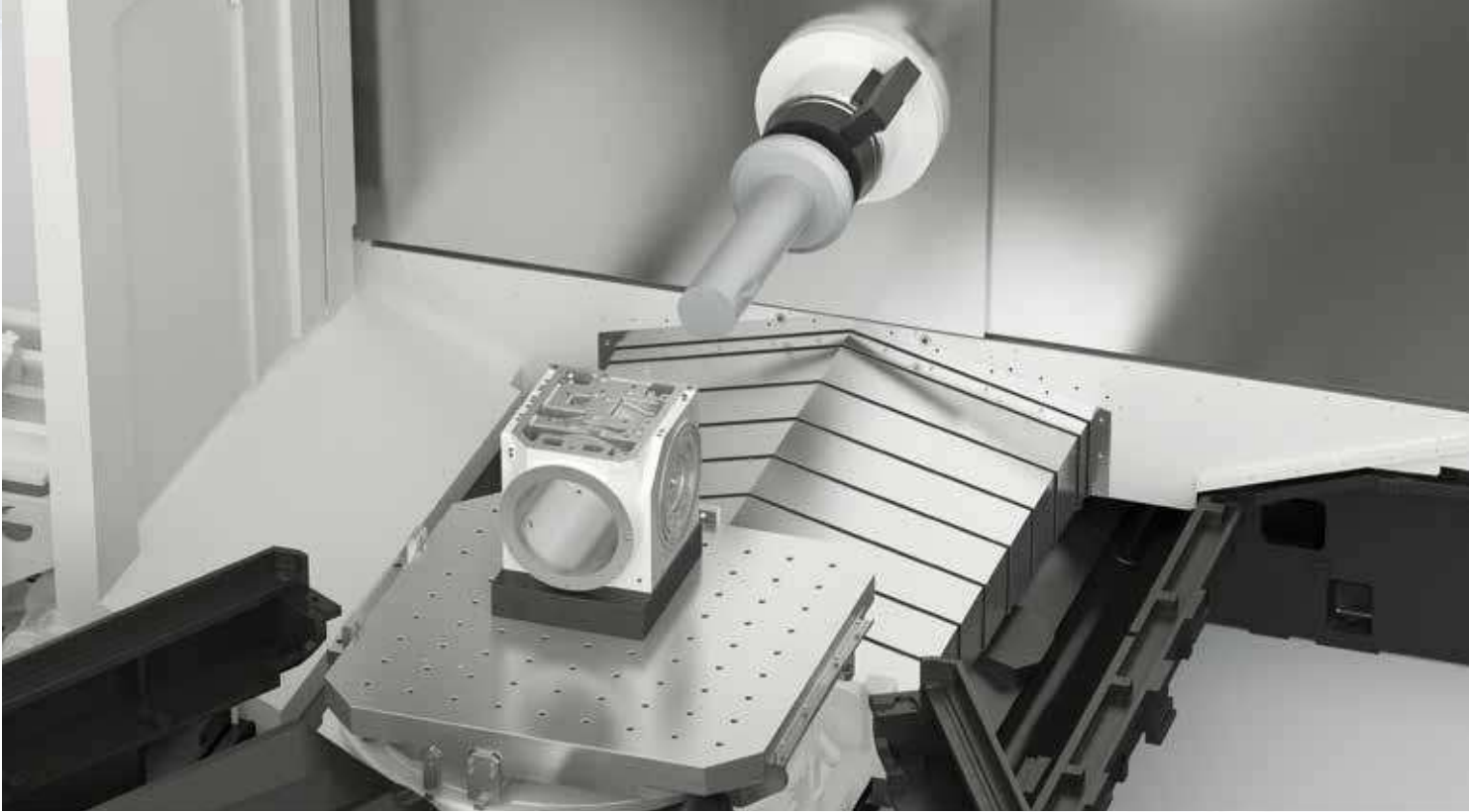

Example

U-axis boring attachment

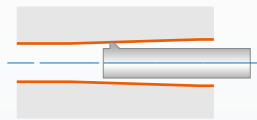
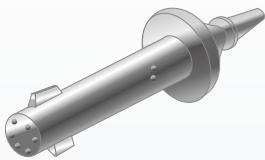

Deep-hole taper boring

Angle attachment

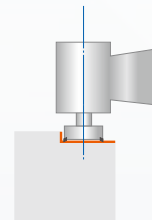
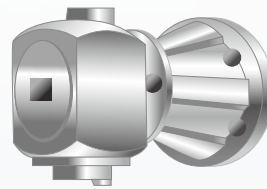

Top surface machining

U-axis facing attachment

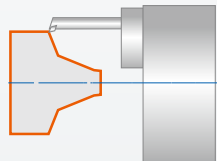
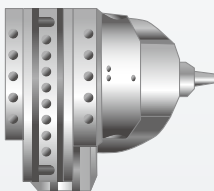

O.D. taper machining

Snout attachment

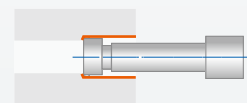
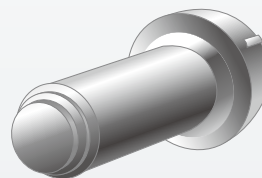

Deep-hole machining

Automation

Automation for enhanced productivity HCN-12500Q, 16000Q, 16800Q

2-pallet changer

The 2-pallet changer allows the unloading of a finished workpiece and the loading of the next workpiece during the machining of the current workpiece.



Machine	Pallet dimensions	Pallet change type	Pallet change time	Max. load (evenly distributed)	Max. workpiece size
HCN-12500Q	1250 mm × 1000 mm (49.21" × 39.37")	Rotary type	60 sec.	5000 kg (11023 lbs)	Φ2350 mm × 1800 mm (Φ92.52" × 70.87")
HCN-16000Q	1600 mm × 1250 mm (62.99" × 49.21")	Shuttle type	115 sec.	8000 kg (17637 lbs)	Φ3000 mm × 2000 mm (Φ118.11" × 78.74")
HCN-16800Q	1600 mm × 1250 mm (62.99" × 49.21")	Shuttle type	115 sec.	8000 kg (17637 lbs)	Φ3000 mm × 2400 mm (Φ118.11" × 94.49")

PALLETECH Manufacturing Cell OPTION

The PALLETECH is designed with the flexibility required for shorter product life cycles, reduced in-process inventory, just-in-time production and other demands of today's manufacturing environment. It is designed for convenient system expansion after the initial installation to easily respond to increased production requirements in the future.

System specifications

	Minimum	Maximum
Machine(s)	1	16
Number of pallets	6	240
Loading station	1	8
Pallet loader	1	1



Higher Productivity



Design focus on ergonomics provides unsurpassed ease of operation

Convenient workpiece loading/unloading

An overhead crane can be easily used for the loading/unloading of heavy workpieces and fixtures.

Improved ease of setup inside machine

For convenient workpiece setup, steps are placed around the machine.



Adjustable CNC operation

The operation touch panel can be tilted to the optimal position for any operator's height to ensure ease of operation.



Remote manual pulse generator

The remote manual pulse generator provides convenient operation when the operator is not close to the CNC operation panel. Its screen shows the position display and the machine coordinate values. Four different positions can be registered in memory by the remote manual pulse generator.

* Wireless type is optionally available.



Standard and Optional Equipment

Coolant system for longer tool life and higher productivity

- Reduces tool wear by controlling temperature rise in tool tip
- Higher quality surface and machining performance thanks to lubrication of tool and workpiece
- Prevents tool damage by removing long chips from tool and workpiece

SUPERFLOW coolant system

- Max. 7 MPa (1015 psi) coolant pressure
- Adjustable coolant pressure
- High-performance cyclone filter with minimum maintenance requirements



High-pressure pump unit



Coolant through spindle

Coolant is fed to the tool tip by passages through the tool.

3 pump pressure specifications are available:

0.8 MPa (120 psi), 1.5 MPa (220 psi) and 7.0 MPa (1015 psi).



Flood coolant

Coolant is discharged from nozzles on the spindle housing to cool workpiece and remove chips.



Niagara coolant

Large-volume coolant is discharged from the nozzles mounted on the machine's top cover to flush chips from the workpiece toward conveyors on both sides of the table.



Fully enclosed splash guard

for HCN-12500QS, 16000QS, 16800QS

This prevents chips and coolant from escaping the machine to ensure a safe and clean working environment.



Standard Pallet Dimensions

Unit: mm (inch)

HCN-12500Q, HCN-12500QS
 1250 mm × 1000 mm (49.21" × 39.37") tapped pallet

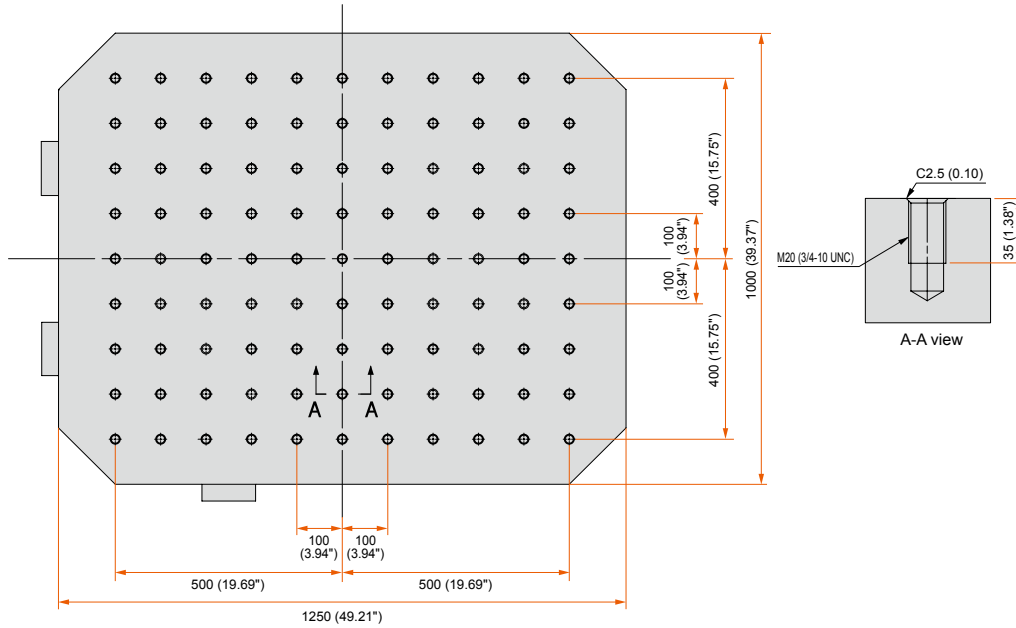

HCN-16000Q, HCN-16800Q, HCN-16000QS, HCN-16800QS
 1600 mm × 1250 mm (62.99" × 49.21") tapped pallet

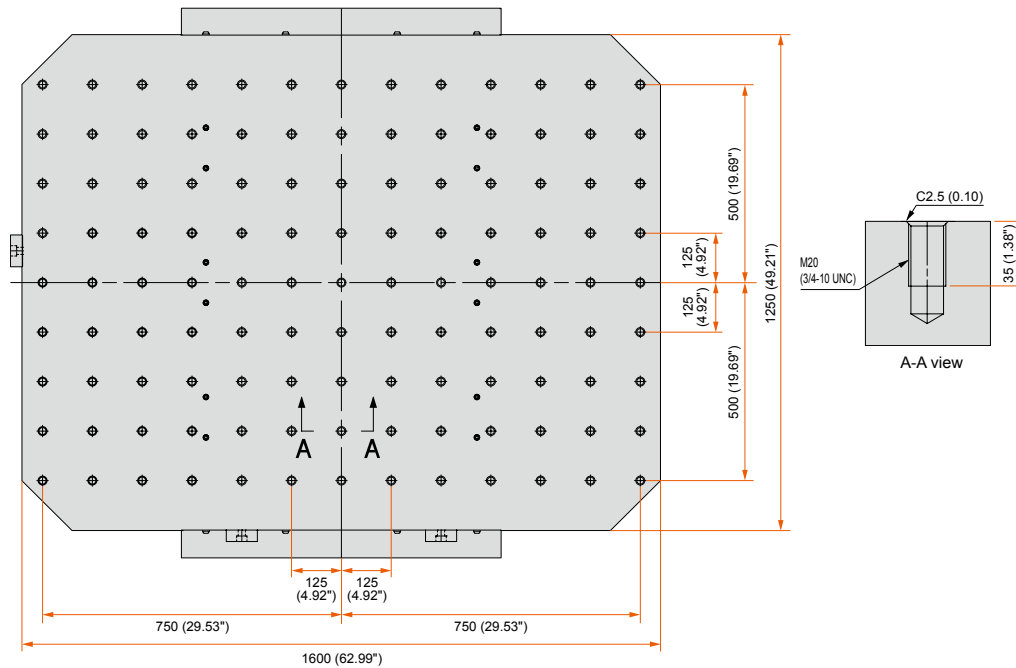

Machine Dimensions

HCN-12500Q

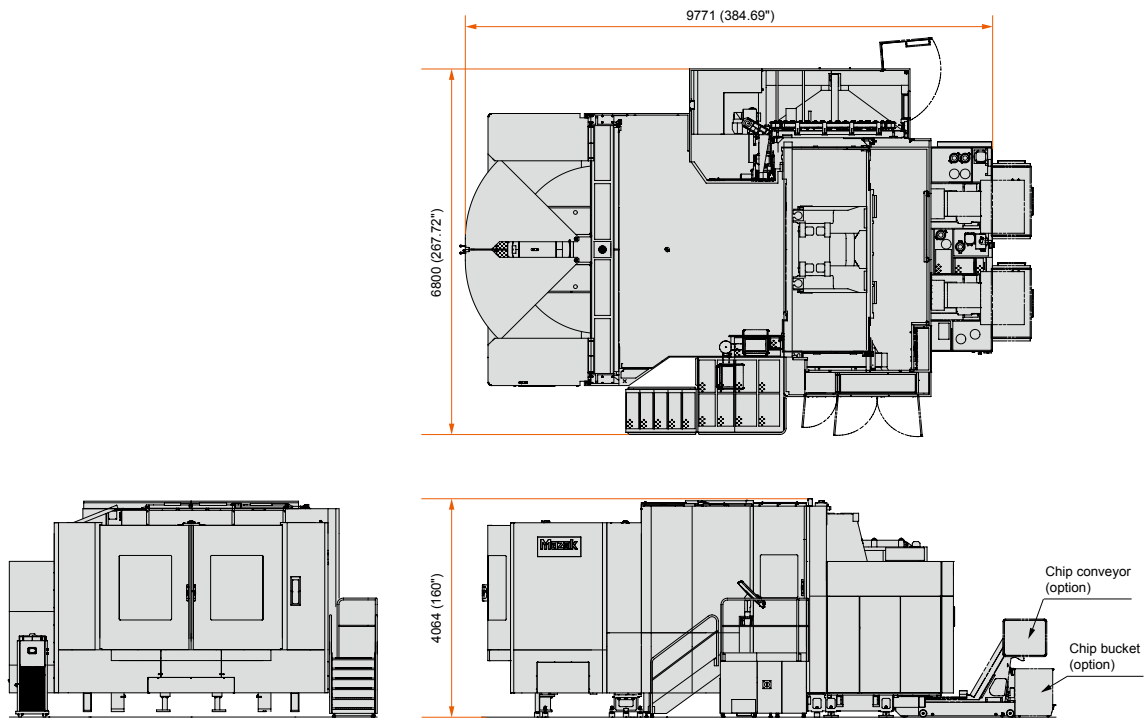

HCN-12500QS

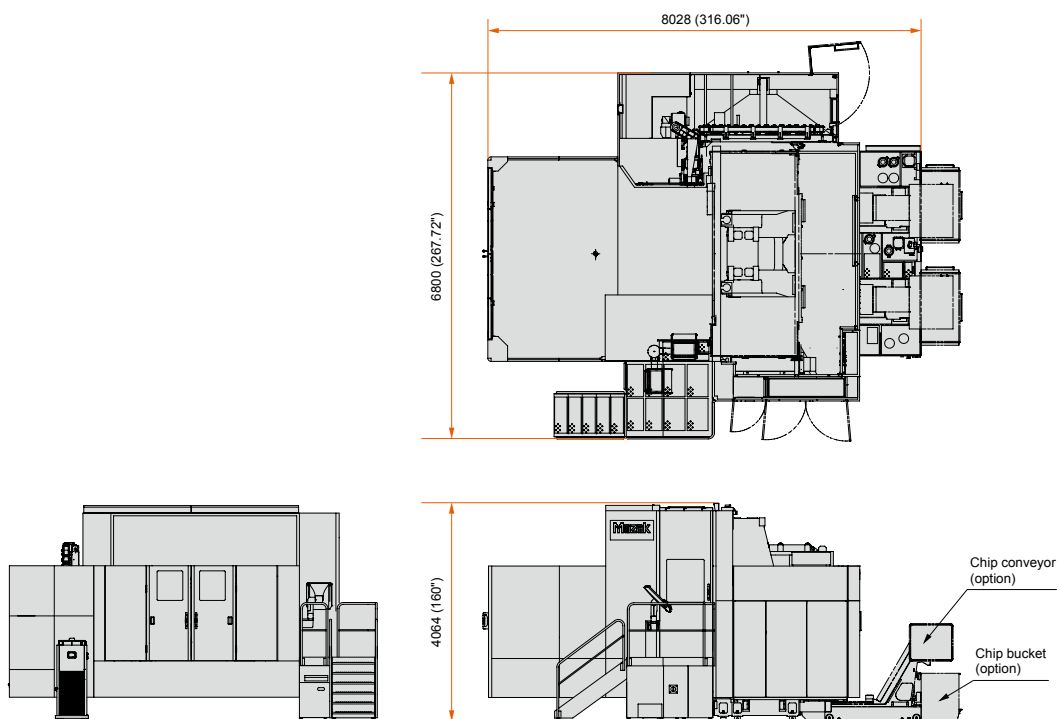

Unit: mm (inch)

HCN-16000Q

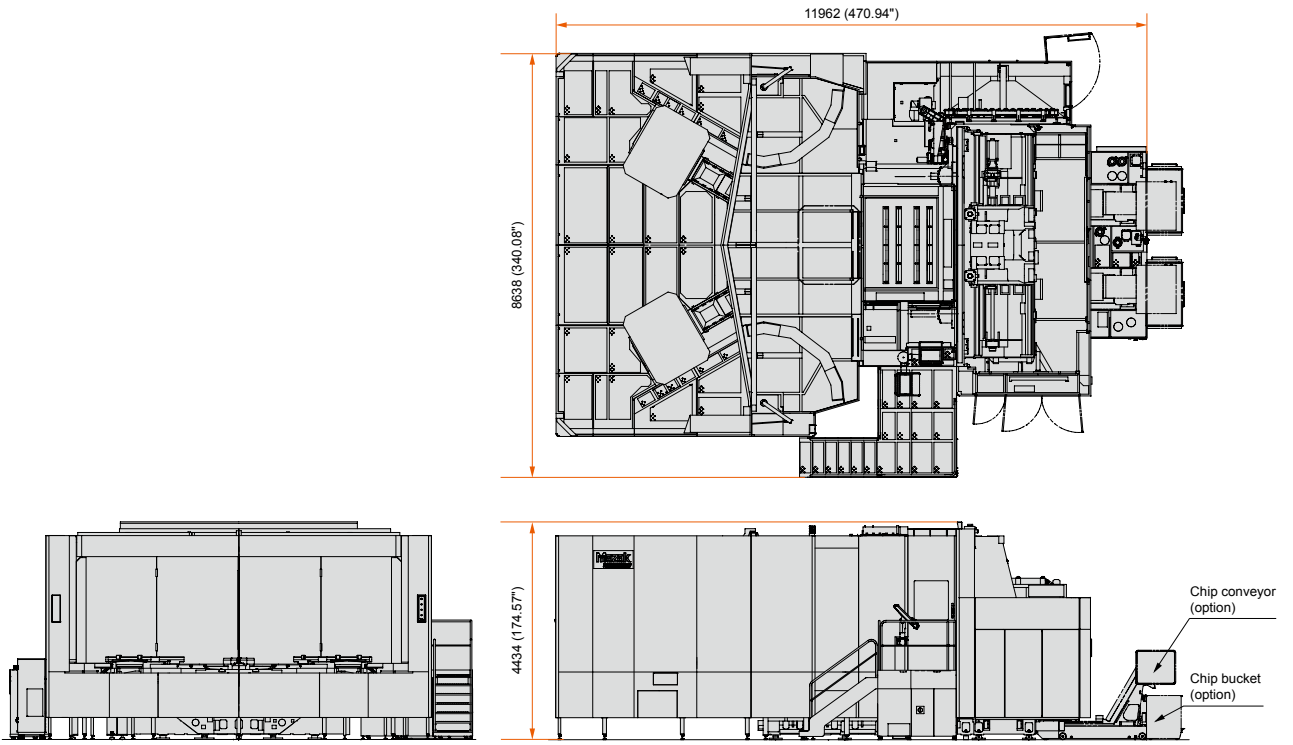

HCN-16000QS

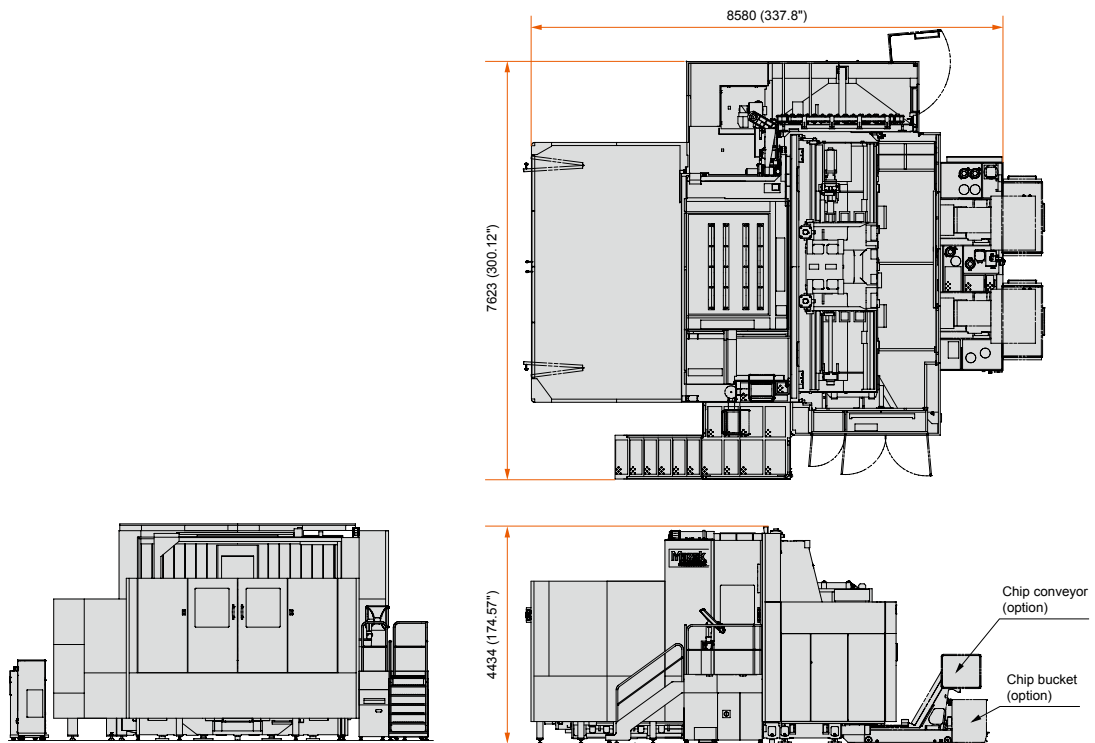

Machine Dimensions

Unit: mm (inch)

HCN-16800Q

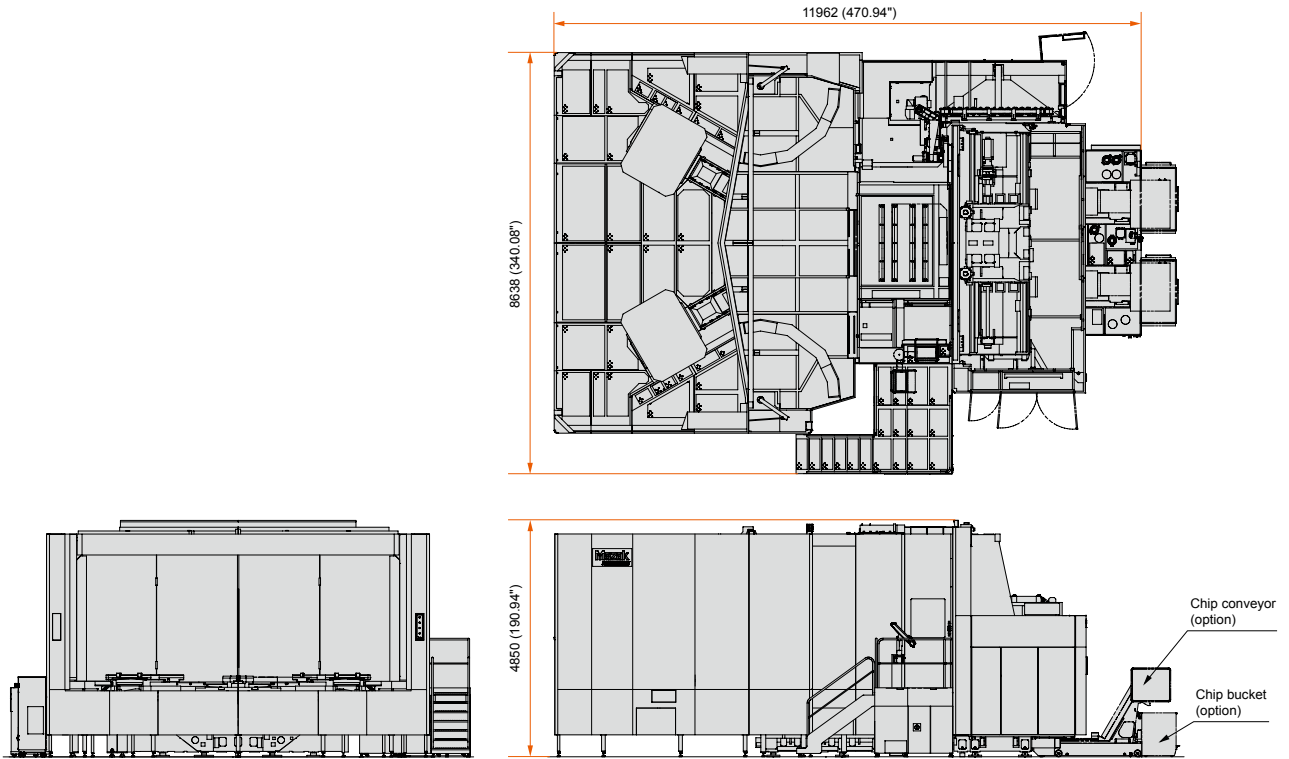

HCN-16800QS

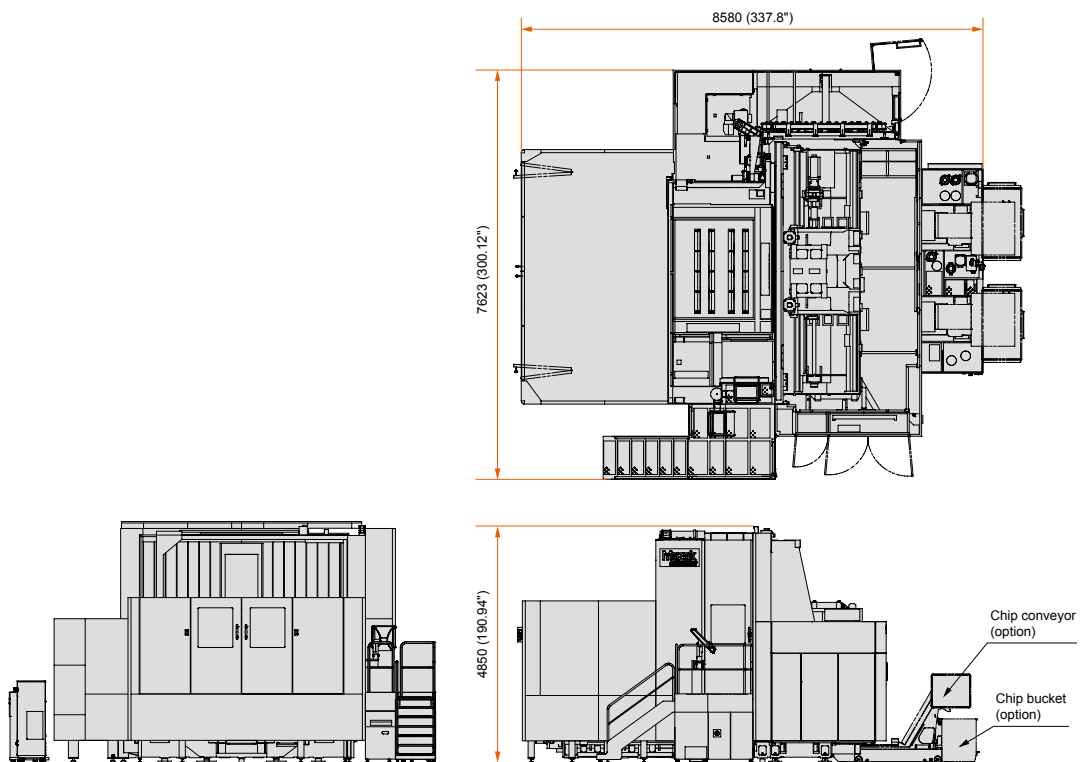

Standard Machine Specifications

		HCN-12500Q	HCN-12500QS	HCN-16000Q	HCN-16000QS	HCN-16800Q	HCN-16800QS
Stroke	X axis (column right/left)	2030 mm (79.92")		2800 mm (110.24")			
	Y axis (spindle up/down)	1400 mm (55.12")	1600 mm (62.99")		2000 mm (78.74")		
	Z axis (table back/forth)	1525 mm (60.04")		1850 mm (72.83")			
	W axis (quill back/forth)	550 mm (21.65")					
	B axis (table rotate)	360° continuous					
	Distance between pallet center to spindle nose	250 mm ~ 1775 mm (9.84" ~ 69.88")		360 mm ~ 2210 mm (14.17" ~ 87.01")			
	Distance between pallet top to spindle center	140 mm ~ 1540 mm (5.51" ~ 60.63")		140 mm ~ 1740 mm (5.51" ~ 68.5")		160 mm ~ 2160 mm (6.30" ~ 85.04")	
Capacity	Max. workpiece dimensions	Φ2350 mm × 1800 mm (Φ92.52" × 70.87")		Φ3000 mm × 2000 mm (Φ118.11" × 78.74")		Φ3000 mm × 2400 mm (Φ118.11" × 94.49")	
	Max. load (evenly distributed)	5000 kg (11023 lbs)		8000 kg (17637 lbs)	10000 kg (22046 lbs)	8000 kg (17637 lbs)	10000 kg (22046 lbs)
Spindle	Max. spindle speed	3000 rpm					
	Spindle gear ranges	2 (electric)					
	Spindle taper	No.50					
	Quill diameter	Φ130 mm (Φ5.12")					
	Milling spindle diameter	Φ180 mm (Φ7.09")					
	Spindle motor (40% ED (30 min. rating)/cont. rating)	45 kW/37 kW (60 HP/50 HP)					
Table	Minimum indexing angle increment	0.0001°					
	Table rotation speed (B axis)	6.8 rpm		6.8 rpm	6.2 rpm	6.8 rpm	6.2 rpm
Pallet	Pallet size	1250 mm × 1000 mm (49.21" × 39.37")		1600 mm × 1250 mm (62.99" × 49.21")			
	Pallet top surface	M20 3/4-10 UNC tapped holes 99 positions 100 mm (4.92") pitch		M20 3/4-10 UNC tapped holes 117 positions 125 mm (4.92") pitch			
Feedrate	Rapid traverse rate (X, Y, Z · W axis)*1	30 m/min · 9 m/min (1181 IPM · 354 IPM)		24 m/min · 9 m/min (945 IPM · 354 IPM)			
	Cutting feedrate (X, Y, Z · W axis)*1	1~30000 mm/min · 1~9000 mm/min (0.04 ~ 1181 IPM · 0.04 ~ 354 IPM)		1~24000 mm/min · 1~9000 mm/min (0.04 ~ 945 IPM · 0.04 ~ 354 IPM)			
Automatic tool changer	Tool shank	CAT-50					
	Pullstud	ANSI					
	Tool storage capacity	80					
	Max. tool diameter/length (from gauge line)/weight	Φ135 mm (Φ5.31")/800 mm (31.5")/30kg (66 lbs)					
	Max. tool diameter with adjacent pockets empty	Φ260 mm*2 (Φ10.24")					
	Tool selection method	Random selection/shortest path					
Automatic pallet changer	Number of pallets	2	—	2	—	2	—
	Pallet change method	Rotary type	—	Shuttle type	—	Shuttle type	—

*1 Limited feedrate with continuous axis movement

*2 When adjacent pockets are empty and pockets next to them have tools less than Φ180 mm (Φ7.09"), maximum tool diameter is Φ360 mm (Φ14.17")

MAZATROL SmoothG Specifications

	MAZATROL	EIA
Number of controlled axes	Simultaneous 2 ~ 4 axes	
Least input increment	0.0001 mm, 0.00001 inch, 0.0001 deg	
High-speed, high-precision control	Shape compensation, Smooth corner control, Rapid traverse overlap, Rotary axis shape compensation	Shape compensation, Smooth corner control, Rapid traverse overlap, Rotary axis shape compensation, High-speed machining mode, High-speed smoothing control
Interpolation	Positioning (interpolation), Positioning (non-interpolation) Linear interpolation, Circular interpolation, Cylindrical interpolation, Polar coordinate interpolation, Synchronous tapping*	Positioning (interpolation), Positioning (non-interpolation) Linear interpolation, Circular interpolation, Spiral interpolation, Helical interpolation, Cylindrical interpolation*, Fine spline interpolation, NURBS interpolation*, Polar coordinate interpolation*, Synchronous tapping*
Feedrate	Rapid traverse, Cutting feed, Cutting feed (per minute), Cutting feed (per revolution), Dwell (time/rotation), Rapid traverse override, Cutting feed override, G0 speed variable control, Feedrate limitation, Variable acceleration control, G00 slope constant*	Rapid traverse, Cutting feed, Cutting feed (per minute), Cutting feed (per revolution), Inverse time feed, Dwell (time/rotation), Rapid traverse override, Cutting feed override, G0 speed variable control, Feedrate limitation, Time constant changing for G1, Variable acceleration control, G00 slope constant*
Program registration	Number of programs: 256 (Standard)/960 (Max.), Program memory: 2 MB, Program memory expansion: 8 MB*, Program memory expansion: 32 MB*	
Control display	Display: 19" touch panel, Resolution: SXGA	
Spindle functions	S code output, Spindle speed limitation, Spindle speed override, Spindle speed reaching detection, Multiple position orient, Constant surface speed, Spindle speed command with decimal digits, Synchronized spindle control, Spindle speed range setting	
Tool functions	Number of tool offset: 4000, T code output for tool number, Tool life monitoring (time), Tool life monitoring (number of machined workpieces)	Number of tool offset: 4000, T code output for tool number, T code output for group number, Tool life monitoring (time), Tool life monitoring (number of machined workpieces)
Miscellaneous functions	M code output, Simultaneous output of multiple M codes	
Tool offset functions	Tool position offset, Tool length offset, Tool diameter/tool nose R offset, Tool wear offset	
Coordinate system	Machine coordinate system, Work coordinate system, Local coordinate system, Additional work coordinates (300 set)	
Machine functions	—	Shaping function, Dynamic compensation II*
Machine compensation	Backlash compensation, Pitch error compensation, Volumetric compensation*	
Protection functions	Emergency stop, Interlock, Pre-move Stroke Check, SAFETY SHIELD (manual mode), SAFETY SHIELD (automatic mode), VOICE ADVISER	
Automatic operation mode	Memory operation	Memory operation, Tape operation, MDI operation, EtherNet operation*
Automatic operation control	Optional stop, Dry run, Manual handle interruption, MD interruption, TPS, Restart, Machine lock	Optional block skip, Optional stop, Dry run, Manual handle interruption, MD interruption, TPS, Restart, Restart 2, Collation stop, Machine lock
Manual measuring functions	Tool length teach, Touch sensor coordinates measurement, Workpiece offset measurement, WPC coordinate measurement, Measurement on machine	Tool length teach, Tool offset teach, Touch sensor coordinates measurement, Workpiece offset measurement, WPC coordinate measurement, Measurement on machine
Automatic measuring functions	WPC coordinate measurement, Automatic tool length measurement, Sensor calibration, Tool breakage detection, External tool breakage detection*	Automatic tool length measurement, Sensor calibration, Tool breakage detection, External tool breakage detection*
MDI measurement	Semi automatic tool length measurement, Full automatic tool length measurement, Coordinate measurement	
Interface	Profibus-DP*, EtherNet/IP*, CC-Link*	
Card interface	SD card interface, USB	
EtherNet	10M/100M/1 Gbps	

*Option

Standard and Optional Equipment

		● : Standard ○ : Option — : N/A					
Machines		12500Q	12500QS	16000Q	16000QS	16800Q	16800QS
Spindle	3000 rpm (CAT-50) spindle quill	●	●	●	●	●	●
Table	NC rotary table	●	●	●	●	●	●
	NC rotary table (with scale)	○	○	○	○	○	○
Pallet	1250 mm × 1000 mm (49.21" × 39.37") tapped pallet	●	●	—	—	—	—
	1250 mm × 1000 mm (49.21" × 39.37") tapped pallet with edge locator	○	○	—	—	—	—
	1250 mm × 1000 mm (49.21" × 39.37") tapped pallet with location bore	○	○	—	—	—	—
	1250 mm × 1000 mm (49.21" × 39.37") T-slot pallet with location bore	○	○	—	—	—	—
	□1250 mm (□49.21") tapped pallet	○	○	—	—	—	—
	□1250 mm (□49.21") tapped pallet with location bore	○	○	—	—	—	—
	□1250 mm (□49.21") T-slot pallet with location bore	○	○	—	—	—	—
	1600 mm × 1250 mm (62.99" × 49.21") tapped pallet	—	—	●	●	●	●
	1600 mm × 1250 mm (62.99" × 49.21") tapped pallet with edge locator	—	—	○	○	○	○
	1600 mm × 1250 mm (62.99" × 49.21") tapped pallet with location bore	—	—	○	○	○	○
	1600 mm × 1250 mm (62.99" × 49.21") T-slot pallet with location bore	—	—	○	○	○	○
	□1600 mm (□62.99") tapped pallet	—	—	○	○	○	○
	□1600 mm (□62.99") tapped pallet with location bore	—	—	○	○	○	○
□1600 mm (□62.99") T-slot pallet with location bore	—	—	○	○	○	○	
Magazine	80-tool magazine	●	●	●	●	●	●
	100-, 120-, 140-, 160-tool magazine	○	○	○	○	○	○
	180, 204, 240, 288, 312, 348 TOOL HIVE (rack-type tool magazine)	○	○	○	○	○	○
	206, 276, 348 TOOLTECH (rack-type tool magazine)	○	○	○	○	○	○
Automation	2-pallet changer	●	—	●	—	●	—
	Tool breakage detection (ATC area)	○	○	○	○	○	○
	Automatic power ON/OFF + warm-up operation	●	●	●	●	●	●
	Automatic attachment changer	○	—	○	—	○	—
	SMOOTH PMC application	○	○	○	○	○	○
Setup	Operator platform/steps by CNC operation panel	●	●	●	●	●	●
	Platform steps at front of machine	○	○	○	○	○	○
	Automatic tool length measurement & tool breakage detection	○	○	○	○	○	○
	Mazak monitoring system B (radio signal) RMP60	○	○	○	○	○	○
Safety equipment	Cover around machining area	—	●	—	●	—	●
	Fully enclosed cover	●	○	●	○	●	○
	Operator door interlock	●	●	●	●	●	●
High accuracy	Ball screw core cooling	●	●	●	●	●	●
	Coolant temperature control	○	○	○	○	○	○
	Scale feedback (X, Y, Z axes)	○	○	○	○	○	○
Coolant/chip disposal	Flood coolant	●	●	●	●	●	●
	Niagara coolant	●	●	●	●	●	●
	Coolant through spindle 0.8 MPa (120 PSI)	○	○	○	○	○	○
	High-pressure coolant through spindle 1.5 MPa (220 PSI)	○	○	○	○	○	○
	SUPERFLOW coolant system	○	○	○	○	○	○
	Work air blast	○	○	○	○	○	○
	Secondary coolant filter for aluminum	○	○	○	○	○	○
	Oil skimmer (RB-200)	○	○	○	○	○	○
	Chip conveyor (rear disposal, hinge)	○	○	○	○	○	○
Chip conveyor (rear disposal, ConSep)	○	○	○	○	○	○	

Above specifications are for North American market.
Standard and optional equipment vary by market.

Mazak

YAMAZAKI MAZAK CORPORATION

1-131 Takeda, Oguchi-cho, Niwa-gun, Aichi-pref., Japan
TEL : +(81)587-95-1131 FAX : +(81)587-95-2717

www.mazak.com

- Specifications are subject to change without notice.
- This product is subject to all applicable export control laws and regulations.
- The accuracy data and other data presented in this catalogue were obtained under specific conditions. They may not be duplicated under different conditions. (room temperature, workpiece materials, tool material, cutting conditions, etc.)

HCN-Q SERIES 17.10.0 A 99Z341517E0

