



**AW MILLER**  
**TECHNICAL SALES, INC.**

EAST AURORA, NY  
716.652.8282

HARMONY, PA  
724.453.1690

STE-LAURENT, QC  
514.333.9174

HARLEYSVILLE, PA  
215.256.8281

# MEGA TURN

SERIES

[ Vertical Turning Center ]

**Mazak**



# MEGA TURN SERIES

## High torque and heavy duty machining

The MEGA TURN series is excellent for turning of thin, large workpiece as well as high efficiency heavy duty machining of large workpieces such as those found in construction machinery and jet engine industries.

Large machining area with minimum interference further enhances machining versatility

---

Designed for heavy-duty machining of large workpieces

---

Mirror-image version available for multiple machine layouts with smaller floor space requirements (Except for 1600,1600M)

---

Automatic tool changer that avoids interference are optionally available with increased the number of tools for higher productivity

---



**MEGA TURN 500M**

Shown with optional equipment



**MEGA TURN 900M**

Shown with optional equipment



## MEGA TURN 1600

Shown with optional equipment

# Extensive Series Range

Increased productivity with large machining area and high-speed, high-accuracy machining



## MEGA TURN 500 SERIES

Max. swing	Φ700 mm (Φ27.56")
Max. machining diameter	Φ500 mm (Φ19.69")
Max. machining height*	462 mm (18.19")
Max. loading capacity	500 kg (1102 lbs) (including chuck weight)
Max. speed	3000 rpm
Number of tools	12

\*Depends on chuck specifications

Increased productivity with large machining area and high-speed, high-accuracy machining



## MEGA TURN 600 SERIES

Max. swing	Φ700 mm (Φ27.56")
Max. machining diameter	Φ630 mm (Φ24.8") (600, 600S) Φ600 mm (Φ23.62") (600M, 600MS)
Max. machining height*	550 mm (21.65")
Max. loading capacity	700 kg (1543 lbs) (including chuck weight)
Max. speed	2200 rpm
Number of tools	12

\*Depends on chuck specifications



High efficiency machining of thin, large workpiece and large cylindrical workpiece

### MEGA TURN 900 SERIES

Max. swing	Φ1000 mm (Φ39.37")
Max. machining diameter	Φ920 mm (Φ36.22")
Max. machining height*	800 mm (31.5")
Max. loading capacity	3000 kg (6614 lbs) (including chuck weight)
Max. speed	1250 rpm
Number of tools	12

\*Depends on chuck specifications



High torque spindle and high rigidity structure are designed to perform powerful machining of large workpieces

### MEGA TURN 1600 SERIES

Max. swing	Φ1650 mm (Φ64.96")
Max. machining diameter	Φ1650 mm (Φ64.96")
Max. machining height*	900 mm (35.43")
Max. loading capacity	5000 kg (11023 lbs) (including chuck weight)
Max. speed	350 rpm
Number of tools	12

\*Depends on chuck specifications

# Higher Productivity

## Unique design for large machining area

The MEGA TURN travelling column design has no cross rail interference to provide a larger machining area than that of comparable machines.

MEGA TURN 500, 500S, 500M, 500MS

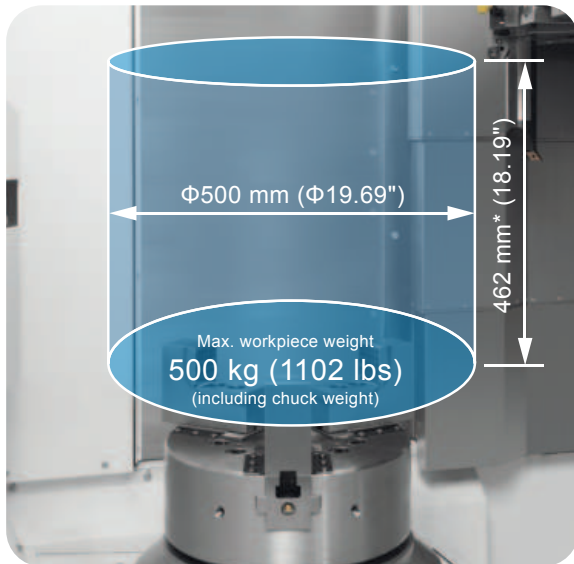

\*Depends on chuck specifications

MEGA TURN 600, 600S, 600M, 600MS

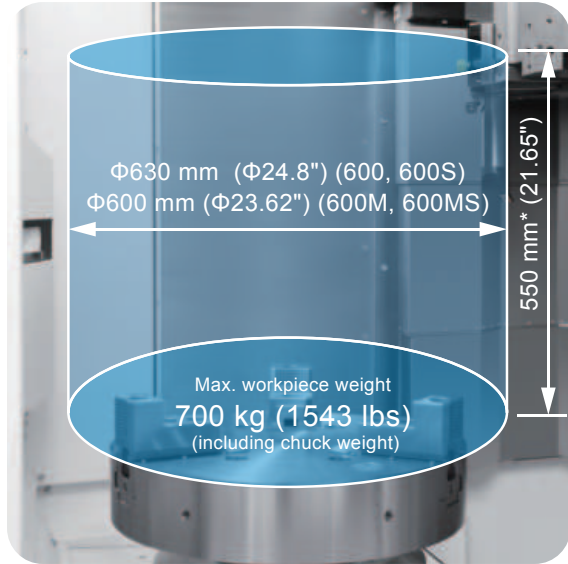

\*Depends on chuck specifications

MEGA TURN 900, 900S, 900M, 900MS

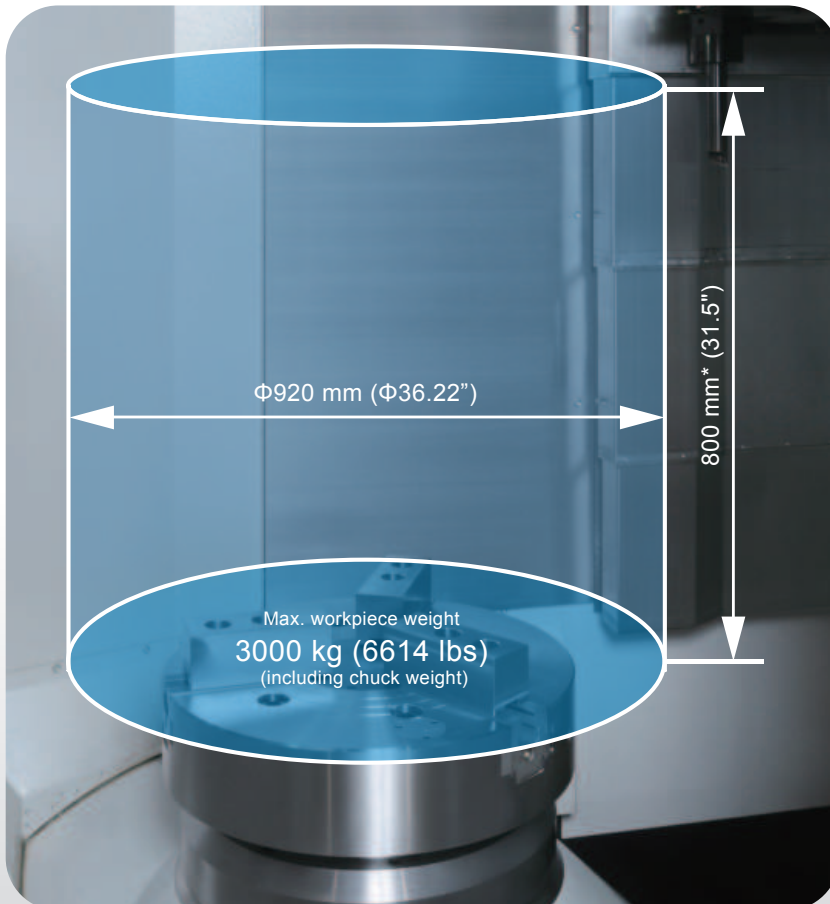

\*Depends on chuck specifications

MEGA TURN 1600, 1600M



\*Depends on chuck specifications

## Machine design comparison

The MEGA TURN has no cross-rail for a larger machining area.

Other manufacturers

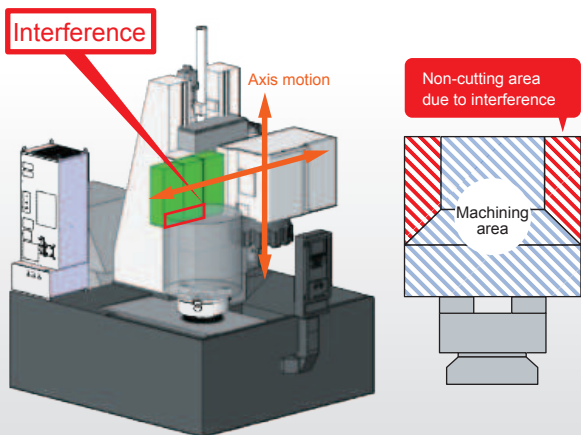

MEGA TURN series

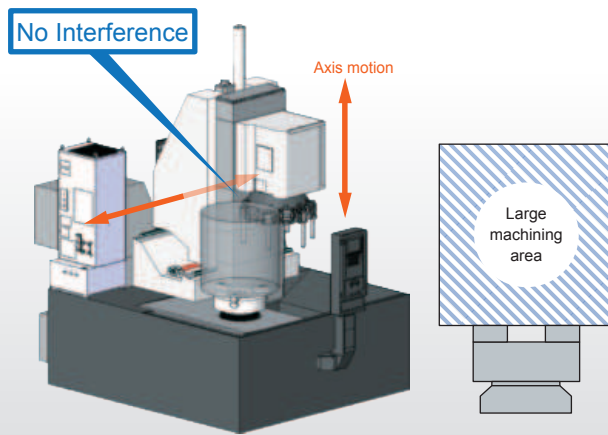

# Higher Productivity

## Rigid integral spindle / motor for unsurpassed machining performance (500, 600 series)

Thanks to its design, vibration is minimized during high speed operation to ensure exceptional surface finishes.

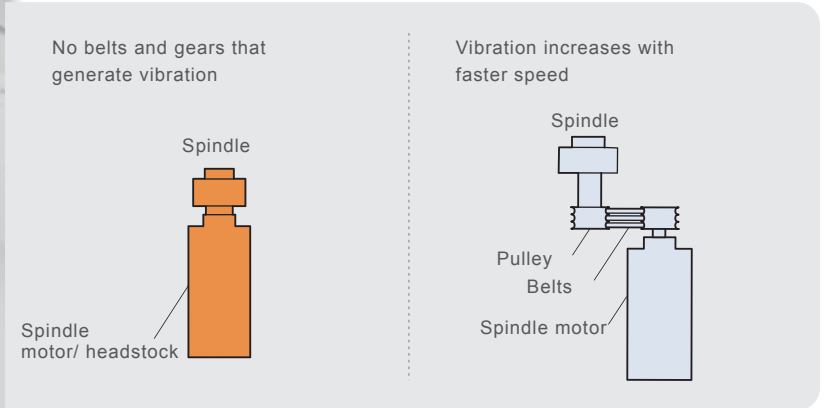

Example results of roundness and surface roughness

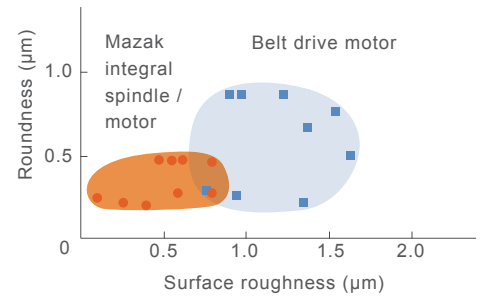

## Integral spindle / motor ensures micron control high accuracy surface finish

Roundness 0.26 µm (0.0000102")

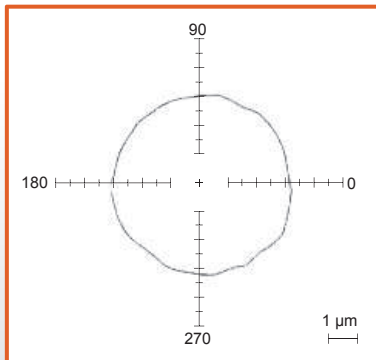

Surface Ra 0.11 µm (0.0000043") Rz 0.66 µm (0.0000260")

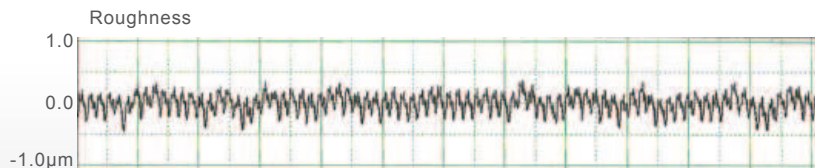

Machine	MEGA TURN 500
DOC	0.02 mm (0.001")
Feedrate	0.03 mm/rev (0.001 IPR)
Spindle speed	500 ~ 2,600 rpm
Workpiece	Φ130 mm × L100 mm (Φ5.12"×3.94")
Tool	Diamond tool R 0.3
Chuck	18 "

Example results for reference only

# Powerful cutting capability for high productivity

High-rigidity spindle for heavy-duty machining of large workpieces



## MEGA TURN 900, 900S, 900M, 900MS

Max. material removal rate : **960 cm<sup>3</sup>/min** (58.6 in<sup>3</sup>/min)

Material: C45 / Spindle speed: 80 rpm / Feedrate: 0.8 mm/rev. (0.03 IPR) / DOC: 8 mm (0.31")

Max. workpiece weight: **3000 kg** (6614 lbs)

Output: **30 kW (40 HP)** [40% ED (30 min.rating)] Max. Torque: **3655 N·m** (2696 ft·lbs)

The high rigidity spindle, with maximum output of 30 kW (40 HP) [40% ED (30 min.rating)], has a maximum torque of 3655 N·m (2696 ft·lbs) for the heavy duty cutting of cast-iron and steel workpieces.

## MEGA TURN 500, 500S, 500M, 500MS 3000 rpm spindle

Spindle output	26 kW □ 35 HP □ [40% ED (30 min.rating)]
	22 kW □ 30 HP □ [Cont. rating]
Max. torque	808 N·m (596 ft·lbs) (15 %ED)
Max. workpiece weight <sup>1</sup>	500 kg (1102 lbs)

<sup>1</sup>Chuck included

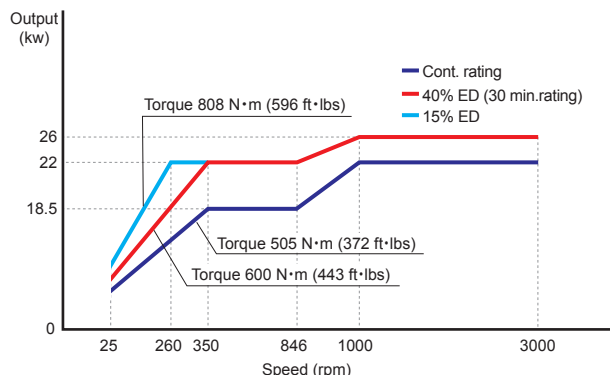

## MEGA TURN 600, 600S, 600M, 600MS 2200 rpm spindle

Spindle output	30 kW □ 40 HP □ [40% ED (30 min.rating)]
	22 kW □ 30 HP □ [Cont. rating]
Max. torque	1000 N·m (738 ft·lbs) (15 %ED)
Max. workpiece weight <sup>1</sup>	700 kg (1543 lbs)

<sup>1</sup>Chuck included

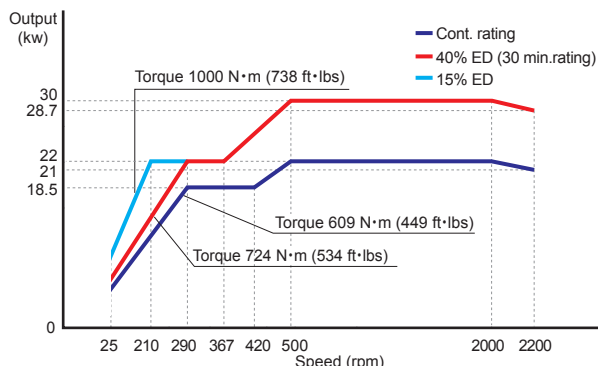

## MEGA TURN 900, 900S, 900M, 900MS 1250 rpm spindle

Spindle output	30 kW □ 40 HP □ [40% ED (30 min.rating)]
	22 kW □ 30 HP □ [Cont. rating]
Max. torque	3655 N·m (2696 ft·lbs) [40% ED (30 min.rating)]
Max. workpiece weight <sup>1</sup>	3000 kg (6614 lbs)

<sup>1</sup>Chuck included

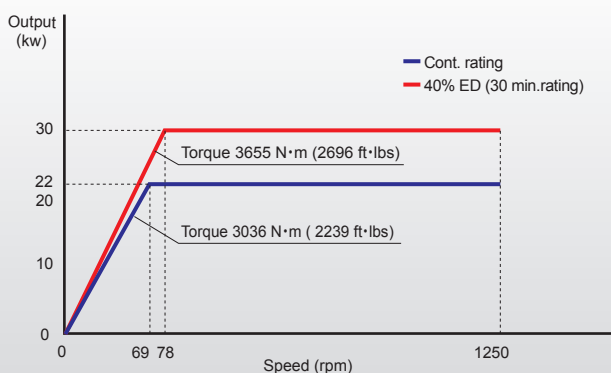

## MEGA TURN 1600, 1600M 350 rpm spindle

Spindle output	45 kW □ 60 HP □ [40% ED (30 min.rating)]
	37 kW □ 50 HP □ [Cont. rating]
Max. torque	10040 N·m (7405 ft·lbs) [40% ED (30 min.rating)]
Max. workpiece weight <sup>1</sup>	5000 kg (11023 lbs)

<sup>1</sup>Chuck included

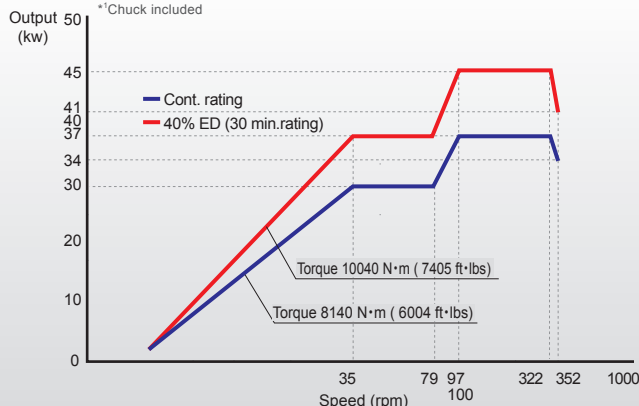

# Higher Productivity

## 12-Position Drum Turret for Heavy-Duty Machining

### 12-position drum turret

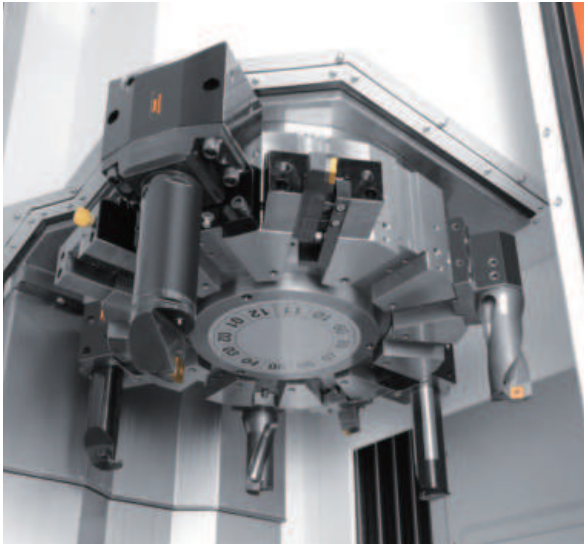

The turret is rigidly clamped by a high-index coupling for high-performance machining including intermittent cutting. Additionally, the turret can hold 12 tools, and is designed for the minimum workpiece interference with boring bars while turning.

	500, 600	900	1600
Number of tools	12 tools (bolt-on)		
Turning and facing tool shank size	25 mm × 150 mm (1" × 5.91") (Option 32 mm × 150 mm (1.25" × 5.91") : 600,600S only)	32 mm × 150 mm (1.25" × 5.91")	32 mm × 170 mm (1.25" × 6.69")
Boring bar shank dia.	Φ50 mm (Φ2")		
Tool selection method	Shortest path, random selection Manual		
Turret indexing time	0.3 sec. / 1 step	0.4 sec. / 1 step	0.5 sec. / 1 step
Turret clamping force	66.1 kN (14860 lbs)	162.7 kN (36597 lbs)	195.5 kN (43950 lbs)

### 12-position drum turret with rotary tools



The MEGA TURN series can combine turning and secondary machining operations in order to efficiently machine large workpieces such as those found in the construction machinery and jet engine industries.

	500M, 600M	900M	1600M
Number of tools	12 tools (bolt-on)	12 tools (VDI type)	12 tools (bolt-on)
Turning and facing tool shank size	25 mm × 150 mm (1" × 5.91") (Option 32 mm × 150 mm (1.25" × 5.91") : 600,600S only)	32 mm × 150 mm (1.25" × 5.91")	32 mm × 170 mm (1.25" × 6.69")
Boring bar shank dia.	Φ50 mm (Φ2")		
Tool selection method	Shortest path, random selection Manual		
Turret indexing time	0.3 sec. / 1 step	0.45 sec. / 1 step	0.5 sec. / 1 step
Turret clamping force	66.1 kN (14860 lbs)	162.7 kN (36597 lbs)	195.5 kN (43950 lbs)

# Automatic Tool Changer for Turning Tools OPTION

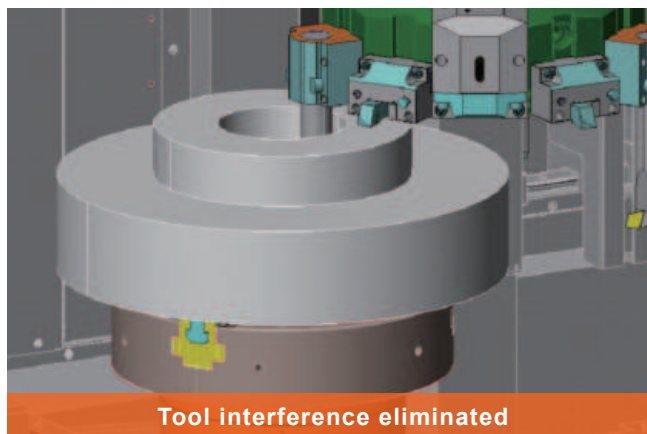
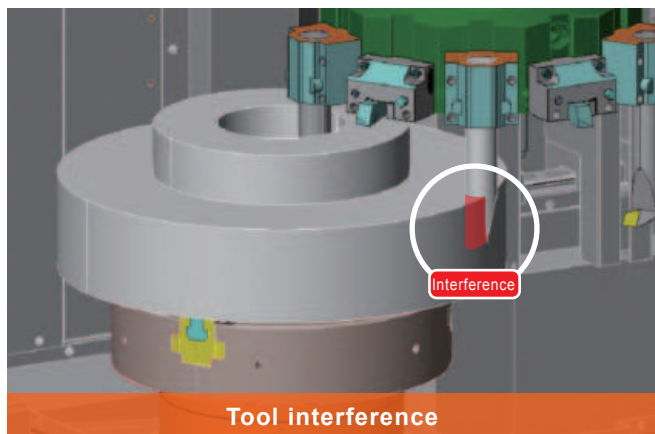

## Automatic tool changer

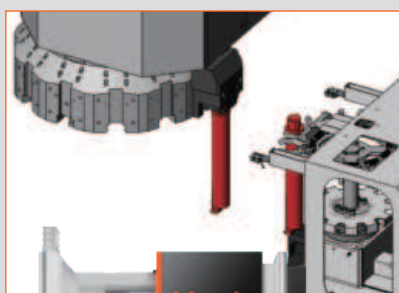

The boring tools can be automatically stored in the adjacent tool magazine. (Turning tools only)

The system eliminates interference with adjacent tools for extremely convenient tool setup. By increasing the number of tools that can be stored, permanent set tooling can be used that meets the requirements of a wide variety of workpieces. Higher productivity is realized by minimizing tool setup when changing workpieces.

## Automatic tool changer specifications

	500	600	900		1600		
Tool shank	<b>CAPTO C6</b>				<b>CAPTO C8</b>		
Number of tools	10 tools		12 tools	24 tools	36 tools	8 tools	12 tools
Max. tool length (from gauge line)	240 mm (9.45")	280 mm (11.02")	410 mm (16.14")			450 mm (17.72")	
Max. tool weight (1 tool)	10 kg (22 lbs)				15 kg (33 lbs)	16 kg (35 lbs)	
Tool selection method	Shortest path, random selection						
Magazine indexing time (1 pocket)	0.5 sec	0.78 sec	0.7 sec	1.1 sec	0.86 sec	0.59 sec	

## Heavy-duty boring (MEGA TURN 500M)

High quality machining is ensured with depth of cut 6 mm (0.24") and feedrate 0.6 mm  $\square$  0.02" / rev

Tool dimension	$\Phi$ 60 mm ( $\Phi$ 2.36") L / D = 3
Workpiece	$\Phi$ 375 mm $\times$ 290 mm ( $\Phi$ 14.76" $\times$ 11.42") ,C45
Cutting speed	130 m/min (426.51 SFM)
Spindle speed	351 rpm
DOC	6 mm (0.24")
Feedrate	0.6 mm (0.02") / rev

Example cutting conditions for reference only



# Higher Productivity & Higher Accuracy

## Milling performance



- High-power 7.5 kW (10 HP) milling spindle
- High-accuracy C-axis positioning
- C-axis contouring

### MEGA TURN 500M, 600M

Milling spindle speed	4000 rpm	
Milling spindle output	AC 7.5 kW □ 10 HP □ □ 10% ED □ AC 5.5 kW □ 7.4 HP □ □ Cont. rating □	
Max. torque	95.4 N·m (70 ft·lbs) [10 %ED]	
Milling capacity	Drill	Φ25 mm (Φ1")
	Endmill	Φ25 mm (Φ1")
	Tap	M24 × 3 (1-8 UNC)

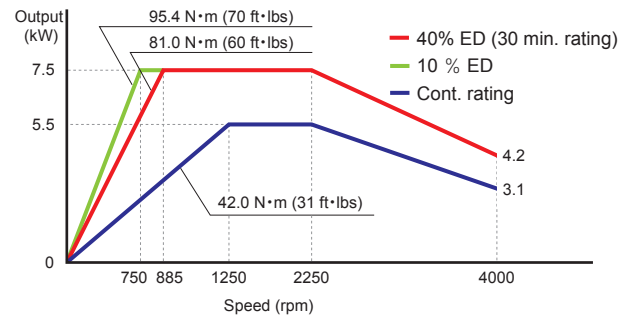

### MEGA TURN 900M

Spindle speed	4000 rpm	
Spindle output	AC 7.5 kW (10 HP) [4 min. rating] AC 1.5 kW (2 HP) [Cont. rating]	
Max. torque	95 N·m (70 ft·lbs) [4 min. rating]	
Milling capability	Drill	Φ25 mm (Φ1")
	End mill	Φ25 mm (Φ1")
	Tap	M24 × 3 (1-8 UNC)

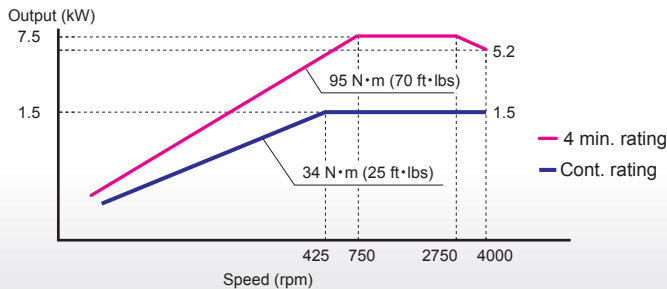

### MEGA TURN 1600M

Spindle speed	3000 rpm	
Spindle output	AC 11 kW (15 HP) [40% ED (30 min. rating)] AC 7.5 kW (10 HP) [Cont. rating]	
Max. torque	140 N·m (103 ft·lbs) [40% ED (30 min. rating)]	
Milling capability	Drill	Φ25 mm (Φ1")
	End mill	Φ25 mm (Φ1")
	Tap	M24 × 3 (1-8 UNC)

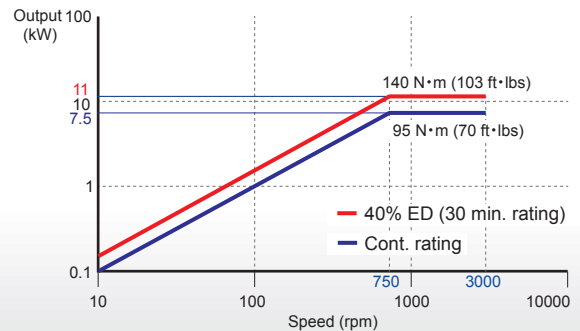

## Positioning accuracy : 2 times better than ISO

MEGA TURN series ensures not only powerful machining but also high accuracy machining.

Unit :  $\mu\text{m}$  (inch)

		X-axis			Z-axis		
		ISO	Mazak standard 2 times better than ISO	Results	ISO	Mazak standard 2 times better than ISO	Results
Bidirectional positioning accuracy	A	22	11 (0.000433")	2.4 (0.000945")	32 (0.00126")	16 (0.00063")	4.8 (0.000189")
Unidirectional positioning accuracy	E $\uparrow$	10	5 (0.000197")	1 (0.0000394")	15 (0.000591")	7.5 (0.000295")	1.6 (0.0000630")
	E $\downarrow$	10	5 (0.000197")	0.9 (0.000354")	15 (0.000591")	7.5 (0.000295")	2.7 (0.000106")
Unidirectional positioning repeatability	R $\uparrow$	6	3 (0.000118")	1.8 (0.0000709")	10 (0.000394")	5 (0.000197")	3.6 (0.000142")
	R $\downarrow$	6	3 (0.000118")	1.5 (0.0000591")	10 (0.000394")	5 (0.000197")	2.7 (0.000106")
Reversal value	B	10	5 (0.000197")	0.4 (0.0000157")	12 (0.000472")	6 (0.000236")	1.6 (0.0000630")

The above results are measured by the MEGA TURN 900 for reference only.

## 2-pallet changer (900 series)

### OPTION

Productivity is increased by the ability to setup the next workpiece during the machining of the current one.



Max. workpiece size	$\Phi 920 \text{ mm} \times \text{H}750 \text{ mm}$ ( $\Phi 36.22" \times \text{H}29.53"$ )
Max. workpiece weight (pallet weight included)	1800 kg (3968 lbs)
Pallet change time	90 sec

Note :

- \*Max. workpiece height depends on chuck specification
- \*Specifications are different when equipped with 2-pallet changer
- \*Manual chuck is only available

# Higher Productivity

## Different machine layouts by combining standard and mirror-image versions (Except for 1600, 1600M)

Distance to be covered by operator is reduced when compared to two standard machines. Floor space is also reduced.

### Available machine layouts



**Adjacent layout**

Since the positions of the openings are closer, the operator's walking distance is shortened.

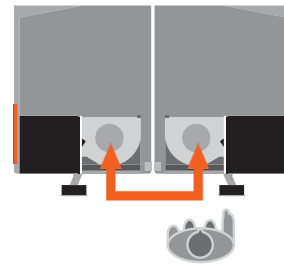

**L-shape layout**

Even floor space is larger than the adjacent layout, the travel distance is shorter.

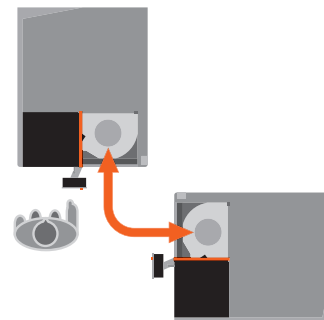

**Opposed machines**

Process flow is easy to understand with shortened travel distance.

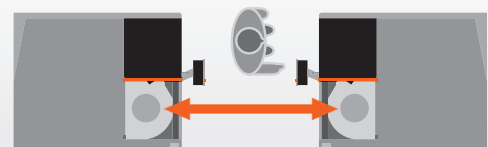



Shown with optional equipment

### Higher efficiency

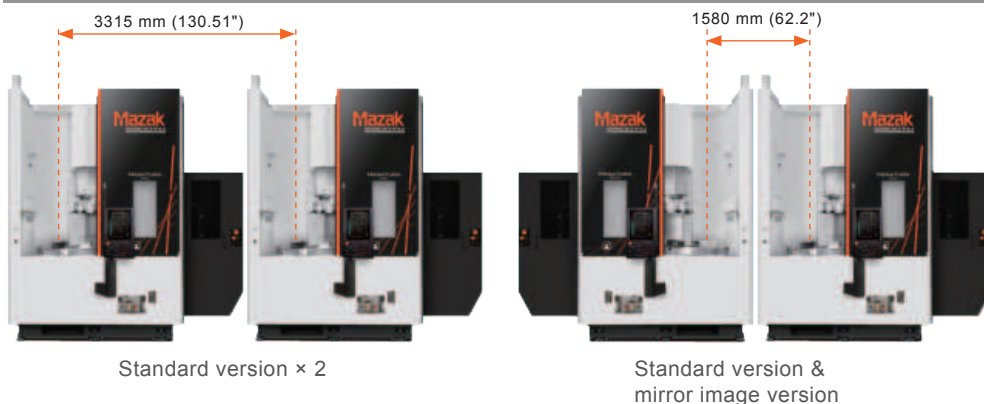

Distance covered by operator is reduced 52% for more convenient transfer of workpieces from machine to machine.

### Minimum floor space

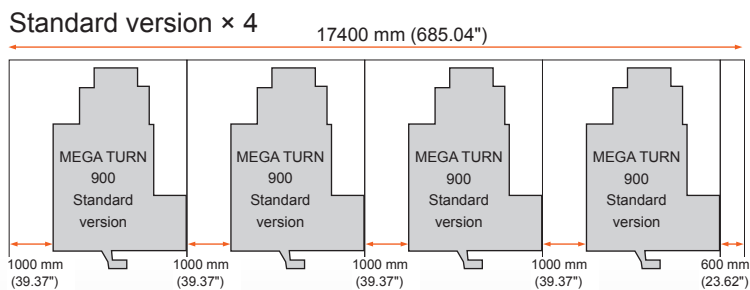

Standard version × 2 & mirror image version × 2

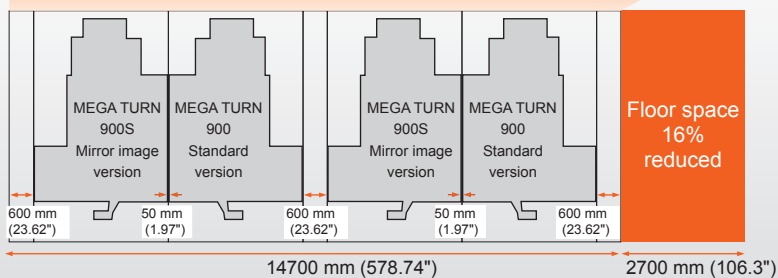

Floor space reduced 16%\* when compared to 2 standard versions and 2 mirror image versions.

\*With automatic tool changer

# Ergonomics

## Ergonomic Design for Convenient Operation

### Excellent accessibility

The operator has excellent access to the table from the front of the machine for convenient workpiece loading / unloading.

### Large window with easy-to-view machining status

The large front window allows workpiece machining to be easily monitored by the operator.



MEGA TURN 500  
Shown with optional equipment

### Maintenance area

Items requiring frequent access for machine maintenance are arranged in one central location.

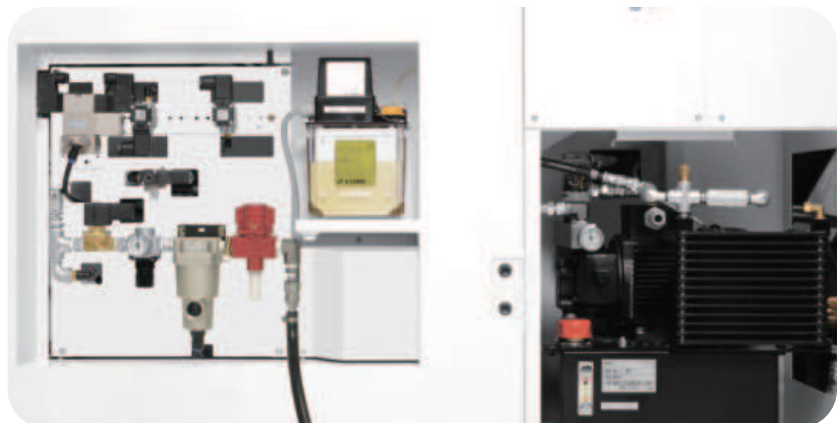

## Convenient access

The MEGA TURN series ensures excellent accessibility to chuck and turret. For ease of operation when loading / unloading workpieces and using an overhead crane, the distance between the spindle center line and the front of the machine is shortened.



## Designed for the smooth flow of machined chips

The steeply-sloping machine base provides a smooth flow of machined chips flushed by the cover coolant into the coolant tank. This prevents the accumulation of machined chips which can affect machine operation.



## Way covers designed for long service life

The unique MEGA TURN series mechanical design includes the way cover design with the minimum number of parts to realize a simplified construction. This ensures convenient maintenance of the wipers to remove jammed machined chips.



## Color coded cables

Cables have a standard color coding for easy identification and convenient maintenance.



Three **Ez (Easy)** features for higher productivity

## MAZATROL *SMOOTH Ez*



### Ez Setup

#### Digital Setup

- Data on a machine in the factory can be accessed from a PC in the office
- Higher operational efficiency

### Ez Machining

#### High-speed high-accuracy machining

- Heat Displacement Control equipped with Thermal Shield

### Ez Operation

- Equipped with "Quick Mazatrol" for enhanced Mazatrol programming
- Intuitive operation with 15" touch screen
- Ease of use has been enhanced with screen design and simple layout customization

## Ez Setup

Virtual machines in your office accurately duplicate the operation of machines on your factory floor. Programs can be made and edited, as well as performing simulation and analysis in your office.

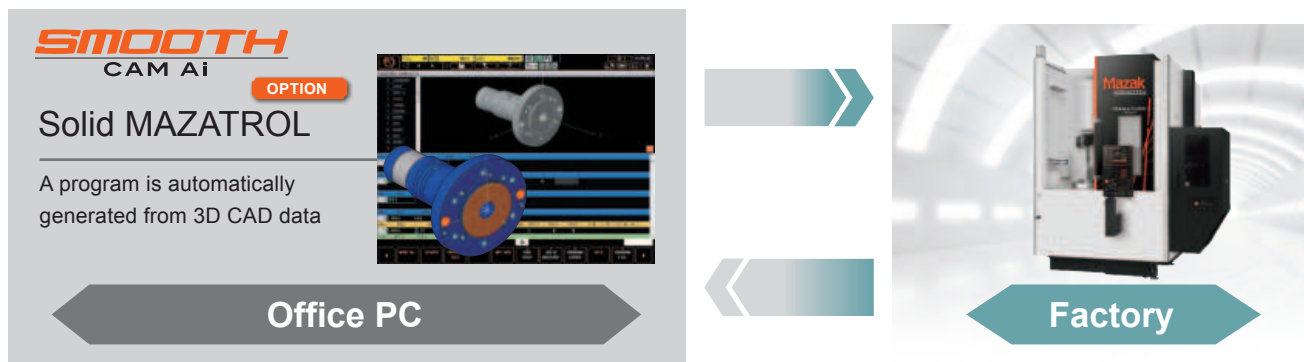

## Ez Operation

### QUICK MAZATROL

Programs can be easily created and checked by displaying the 3D model of the workpiece.

Easily edit a program by touching the display

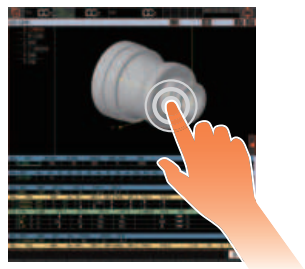

### CUSTOM DISPLAY

Displayed data position can be changed in the CNC screen for ease of operation.



Data can be checked and set with minimum screen transition by customizing the display according to operation process.

Customized display  
 • Tool data  
 • Setup information

## Ez Machining

### HEAT DISPLACEMENT CONTROL THERMAL SHIELD

Mazak has performed extensive testing in a variety of environments in a temperature controlled room and has used the results to develop a control system that automatically compensates for temperature changes in the machining area.

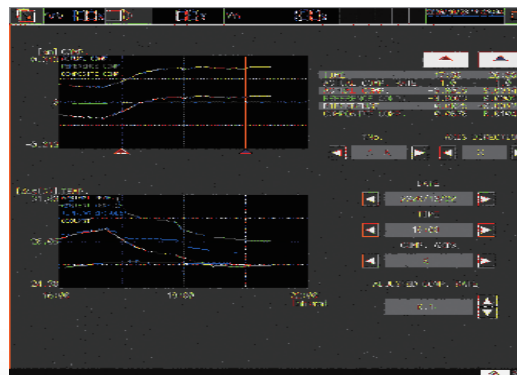

## Standard Machine Specifications

		MEGA TURN 500, 500S	MEGA TURN 500M, 500MS	MEGA TURN 600, 600S	MEGA TURN 600M, 600MS
Capacity	Max. swing	Φ700 mm (Φ27.56")			
	Max. machining diameter	Φ500 mm (Φ19.69")		Φ630 mm (Φ24.8")	Φ600 mm (Φ23.62")
	Max. machining height <sup>1</sup>	462 mm (18.19")		550 mm (21.65")	
	Max. loading capacity <sup>2</sup>	500 kg (1102 lbs)		700 kg (1543 lbs)	
Stroke	X-axis (turret right / left)	345 mm (13.58")			
	Z-axis (turret up / down)	520 mm (20.47")			
	Distance from spindle face to turret face	165.5 mm ~ 680.5 mm (6.52"~26.79")		273.5 mm ~ 788.5 mm (10.77"~31.04")	
Spindle	Chuck size	Option : 12",15",18"		Option : 18",21",24"	
	Spindle speed <sup>1</sup>	3000 rpm		2200 rpm	
	Gear ranges	1-stepless			
	Max. torque	808 N·m (596 ft-lbs)		1000 N·m (738 ft-lbs)	
	Min. indexing angle increment (C-axis)	—	0.0001°	—	0.0001°
	Spindle nose	A2-11			
Turret	Type	12 position drum turret (bolt-on)			
	Number of tools	12 tools			
	Tool shank (O.D)	25 mm (1")		25 mm (1") (32 mm (1.25") option)	
	Tool shank (I.D)	Φ50 mm (Φ2")			
	Turret indexing time	0.3 sec / 1 step			
Rotary tool spindle	Spindle speed	—	4000 rpm	—	4000 rpm
	Max. torque	—	95.4 N.m (70 ft-lbs)	—	95.4 N.m (70 ft-lbs)
	Milling capability	—	Drill : Φ25 mm (Φ1"), Endmill : Φ25 mm (Φ1"), Tap : M24×3 [1-8 UNC]	—	Drill : Φ25 mm (Φ1"), Endmill : Φ25 mm (Φ1"), Tap : M24×3 [1-8 UNC]
Feedrate	Rapid traverse rate : X-axis	30 m/min (1181 IPM)			
	Rapid traverse rate : Z-axis	30 m/min (1181 IPM)			
	Rapid traverse rate : C-axis	—	75 rpm	—	50 rpm
Motors	Spindle motor (40% ED (30 min. rating) / cont. rating)	26 kW / 22 kW 35 HP / 30 HP		30 kW / 22 kW 40 HP / 30 HP	
	Milling spindle motor (10% ED)	—	7.5 kW / 10 HP	—	7.5 kW / 10 HP
	Coolant pump motor	0.52 kW 0.7 HP			
Power requirement	Required power capacity (30 min. rating / cont. rating)	44.5 kVA / 38.76 kVA		50.2 kVA / 38.74 kVA	
	Air supply	0.5 MPa (73 PSI), 10 L /min (0.35 ft <sup>3</sup> /min)	0.5 MPa (73 PSI), 60 L /min (2.12 ft <sup>3</sup> /min)	0.5 MPa (73 PSI), 10 L /min (0.35 ft <sup>3</sup> /min)	0.5 MPa (73 PSI), 60 L /min (2.12 ft <sup>3</sup> /min)
Coolant	Tank capacity <sup>3</sup>	329 L (87 gal)			
Machine size	Height	2990 mm (117.72")		3000 mm (118.11")	
	Floor space <sup>4</sup>	1850 mm × 2370 mm (72.83"×93.91")			
	Machine weight	9250 kg (20392 lbs)		9800 kg (21605 lbs)	

<sup>1</sup> Depends on chuck specifications

<sup>2</sup> Including chuck weight

<sup>3</sup> When rear-hinge chip conveyor (CT -20) equipped

<sup>4</sup> CNC control and coolant tank dimensions are not included

		MEGA TURN 900, 900S	MEGA TURN 900M, 900MS	MEGA TURN 1600	MEGA TURN 1600M	
Capacity	Max. swing* <sup>1</sup>	Φ1000 mm (Φ39.37")		Φ1650 mm (Φ64.96")		
	Max. machining diameter	Φ920 mm (36.22")		Φ1650 mm (Φ64.96")		
	Max. machining height* <sup>2</sup>	800 mm (31.50")		900 mm (35.43")		
	Max. loading capacity* <sup>3</sup>	3000 kg (6614 lbs)		5000 kg (11023 lbs)		
Stroke	X-axis (turret right / left)	470 mm (18.50")		1140 mm (44.88")		
	Z-axis (turret up / down)	876 mm (34.49")		905 mm (35.63")		
	Distance from spindle face to turret face	154 mm ~ 1030 mm (6.06" ~ 40.55")	163 mm ~ 1039 mm (6.42" ~ 40.91")	193 mm ~ 1098 mm (7.6" ~ 43.23")	157 mm ~ 1062 mm (6.18" ~ 41.81")	
Spindle	Chuck size	Option : 21", 24", 28", 32", 36"		Option : Φ1250 mm (Φ49.21"), Φ1500 mm (Φ59.06")		
	Spindle speed* <sup>2</sup>	1250 rpm		350 rpm		
	Gear ranges	1-stepless				
	Max. torque	3655 N·m (2696 ft-lbs)		10040 N·m (7405 ft-lbs)		
	Min. indexing angle increment (C-axis)	—	0.0001°	—	0.0001°	
	Spindle nose	A2-15		Φ540 H7		
Turret	Type	12 position drum turret (bolt-on)	12 position drum turret (VDI type)	12 position drum turret (bolt-on)		
	Number of tools	12 tools				
	Tool shank height	32 mm (1.25")				
	Boring bar shank diameter	Φ 50 mm (Φ2")				
	Turret indexing time	0.4 sec / 1 step		0.5 sec / 1 step		
Rotary tool spindle	Spindle speed	—	4000 rpm	—	3000 rpm	
	Max. torque	—	95 N·m (70 ft-lbs)	—	140 N·m (103 ft-lbs)	
	Milling capability	—	Drill:Φ25 mm (Φ1"), Endmill:Φ25 mm (Φ1"), Tap:M24 × 3 (1-8 UNC)	—	Drill:Φ25 mm (Φ1"), Endmill:Φ25 mm (Φ1"), Tap:M24 × 3 (1-8 UNC)	
Feedrate	Rapid traverse rate : X-axis	24 m/min (945 IPM)				
	Rapid traverse rate : Z-axis	24 m/min (945 IPM)				
	Rapid traverse rate : C-axis	—	20 rpm	—	20 rpm	
Motors	Spindle motor (30 min. rating / cont. rating)	30 kW / 22 kW 40 HP / 30 HP		45 kW / 37 kW 60 HP / 50 HP		
	Milling spindle motor	—	7.5 kW 10 HP (4 min. rating)	—	11 kW 15 HP (40% ED (30 min. rating) )	
	Coolant pump motor	1.04 kW 1.38 HP				
Power requirement	Required power capacity (30 min. rating / cont. rating)	52.71 kVA / 41.25 kVA		77.28 kVA / 65.93 kVA		
	Air supply	0.5 MPa (71 PSI), 30 L/min (1.06 ft <sup>3</sup> /min) (ANR)	0.5 MPa (71 PSI), 150 L/min (5.3 ft <sup>3</sup> /min) (ANR)	0.5 MPa (71 PSI), 30 L/min (1.06 ft <sup>3</sup> /min) (ANR)	0.5 MPa (71 PSI), 70 L/min (2.47 ft <sup>3</sup> /min) (ANR)	
Coolant	Tank capacity* <sup>4</sup>	516 L (136 gal)		690 L (182 gal)		
Machine size	Height* <sup>5</sup>	3400 mm (133.86") [ Max. height of counterbalance : 3658.7 mm (144.04") ]		3474 mm (136.77") [ Max. height of counterbalance : 3692 mm (145.35") ]		
	Floor space* <sup>6</sup>	2375 mm × 2975 mm (93.50"×117.13")		4140 mm × 3222 mm (162.99" × 126.85")		
	Machine weight	14000 kg (30864 lbs)		25000 kg (55115 lbs)		

\*<sup>1</sup> Limitations with X-axis stroke\*<sup>2</sup> Depends on chuck specifications\*<sup>3</sup> Including chuck weight\*<sup>4</sup> 900 series : when hinge chip conveyor (MT-10) equipped  
1600 series : when hinge chip conveyor (CT -20) equipped\*<sup>5</sup> Max. height of counterbalance depends on Z-axis position\*<sup>6</sup> CNC control and coolant tank dimensions are not included.

# Standard and Optional Equipment

## Tool eye

The tool eye can be programmed for automatic tool measurement and compensation as well as inspection for tool breakage. Tool setup time is considerably reduced as tool setup is done by simply bringing the tool tip into contact with the tool eye.



## Remote manual pulse generator

OPTION

Remote manual pulse generator, axis selecting switch and emergency stop button are on remote operation panel for more convenient machine setup.



## SUPERFLOW coolant system

OPTION

The SUPERFLOW coolant system features lower tool tip temperatures, improved coolant lubrication and chip disposal by supplying a maximum 7.0 MPa (1015 PSI) coolant pressure.



High pressure pump unit



## Standard and Optional Equipment

		● : Standard ○ : Option — : N/A			
		MEGA TURN 500, 500S	MEGA TURN 500M, 500MS	MEGA TURN 600, 600S	MEGA TURN 600M, 600MS
Machine	Work light	●	●	●	●
	12" non through-hole chuck NV12	○	○	-	-
	15" non through-hole chuck NV15	○	○	-	-
	18" non through-hole chuck NV18	○	○	○	○
	21" non through-hole chuck NV21	-	-	○	○
	24" non through-hole chuck NV24	-	-	○	○
	Spindle orient	●	●	●	●
	0.0001° indexing	-	●	-	●
	C-axis contouring	-	●	-	●
	300 mm raised step	○	○	○	○
	Remote manual pulse generator	○	○	○	○
	Rotating CNC operation panel raised 300 mm (11.81")	○	○	○	○
	Factory Automation	Absolute positioning detection system	●	●	●
Robot interface		○	○	○	○
Automatic tool changer CAPTO C6 (10 tool magazine)		○	○	○	○
Tool eye		●	●	●	●
Automatic chuck jaws open / close		○	○	○	○
Chuck jaw air blast		○	○	○	○
High / low chuck pressure system		○	○	○	○
Automatic front door open / close		○	○	○	○
Automatic power off		●	●	●	●
Calendar automatic power on / off and warm-up operation		○	○	○	○
Machining end buzzer		○	○	○	○
Status light (1 color)		○	○	○	○
Status light (3 colors)		○	○	○	○
Safety equipment	Chuck open / close confirmation (when equipped with hydraulic chuck)	●	●	●	●
	Hydraulic pressure interlock	●	●	●	●
	Operator door interlock	●	●	●	●
	Overload detection system	○	○	○	○
	Double foot pedal chuck switch	○	○	○	○
Coolant / chip disposal	Mist collector	○	○	○	○
	Turret air blast	○	○	○	○
	Shower coolant system	●	●	●	●
	High-power coolant 520 W	●	●	●	●
	High-power coolant 1.1 kW	○	○	○	○
	High pressure coolant system 1.5 MPa (218 PSI)	○	○	○	○
	SUPERFLOW coolant system	○	○	○	○
	Rear discharge chip conveyor (hinge)	○	○	○	○
	Rear discharge chip conveyor (ConSep2000WS)	○	○	○	○
	Chip conveyor (side discharge, hinge)	○	○	○	○
Chip bucket	○	○	○	○	

## Standard and Optional Equipment

● : Standard ○ : Option — : N/A

		900	900S	900M	900MS
Machine	Work light	●	●	●	●
	21"non-through hole with 3- jaw chuck NV-21C1515	○	○	○	○
	24"non-through hole with 3- jaw chuck NV-24C1515	○	○	○	○
	28"non-through hole with 3- jaw chuck NV-28C1515	○	○	○	○
	32"non-through hole with 3- jaw chuck NV-32C1515	○	○	○	○
	36"non-through hole with 3- jaw chuck NV-36C1515	○	○	○	○
	24" with 3-jaw scroll chuck	○	○	○	○
	32" with 3-jaw scroll chuck	○	○	○	○
	36" with 3-jaw scroll chuck	○	○	○	○
	24" with 4-jaw independent chuck	○	○	○	○
	32" with 4-jaw independent chuck	○	○	○	○
	36" with 4-jaw independent chuck	○	○	○	○
	Spindle orient	○	○	○	○
	0.0001° indexing	-	-	●	●
	Remote manual pulse generator	○	○	○	○
	Rotating CNC operation panel raised 300 mm (11.81")	○	○	○	○
Factory automation	Absolute positioning detection system	●	●	●	●
	Robot interface	○	○	○	○
	2-pallet changer	○	○	○	○
	Automatic tool changer CAPTO C8 (8 tool magazine)	○	○	○	○
	Automatic tool changer CAPTO C6 (12 tool magazine)	○	○	○	○
	Automatic tool changer CAPTO C6 (24 tool magazine)	○	○	○	○
	Automatic tool changer CAPTO C6 (36 tool magazine)	○	○	○	○
	Tool eye	●	●	●	●
	Automatic chuck jaw clamp / unclamp	○	○	○	○
	Chuck jaw air blast	○	○	○	○
	High / low chuck pressure system	○	○	○	○
	Automatic front door open / close	○	○	○	○
	Automatic power off	●	●	●	●
	Calendar type automatic power on / off and warm-up operation	○	○	○	○
	Machining end buzzer	○	○	○	○
	Status light (1 color)	○	○	○	○
Status light (3 colors)	○	○	○	○	
Safety equipment	Chuck open / close confirmation (when equipped with hydraulic chuck)	●	●	●	●
	Hydraulic pressure interlock	●	●	●	●
	Operator door interlock	●	●	●	●
	Overload detection system	○	○	○	○
	Double foot pedal chuck switch	○	○	○	○
Coolant / chip disposal	Coolant system	●	●	●	●
	Mist collector	○	○	○	○
	Turret air blast	○	○	○	○
	Coolant temperature control	○	○	○	○
	High power coolant 1.1 kW (1.2 kW for cover)	●	●	●	●
	1.5 MPa (218 PSI) high pressure coolant 2.2 kW (50 Hz) / 3.0 kW (60 Hz) (1.2 kW for cover)	○	○	○	○
	SUPERFLOW coolant system	○	○	○	○
	Rear discharge chip conveyor (hinge)	○	○	○	○
	Rear discharge chip conveyor (ConSep2000WS)	○	○	○	○
	Chip bucket	○	○	○	○

● : Standard ○ : Option — : N/A

		1600	1600M
Machine	Work light	●	●
	Φ1250 mm (Φ49.21") faceplate (including 4 jaws)	○	○
	Φ1500 mm (Φ59.06") faceplate (including 4 jaws)	○	○
	4-jaw independent chuck dia.1250 mm (49.21")	○	○
	4-jaw independent chuck dia.1500 mm (59.06")	○	○
	3-jaw non-through hole hydraulic chuck dia.1250 mm (49.21")	○	○
	3-jaw non-through hole hydraulic chuck dia.1500 mm (59.06")	○	○
	Spindle orient	○	○
	0.0001° indexing	-	●
	Remote manual pulse generator	○	○
Factory automation	Absolute positioning detection system	●	●
	Robot interface	○	○
	Automatic tool changer CAPTO C8 (12 tool magazine)	○	○
	Tool eye	●	●
	Automatic chuck jaw clamp / unclamp	○	○
	Chuck jaw air blast	○	○
	High / low chuck pressure system	○	○
	Automatic front door open / close	●	●
	Automatic power off	●	●
	Calendar type automatic power on / off and warm-up operation	○	○
	Machining end buzzer	○	○
	Status light (1 color)	○	○
	Status light (3 colors)	○	○
Safety equipment	Chuck open / close confirmation (when equipped with hydraulic chuck)	●	●
	Hydraulic pressure interlock	●	●
	Operator door interlock	●	●
	Overload detection system	○	○
	Double foot pedal chuck switch	○	○
Coolant / chip disposal	Coolant system	●	●
	Mist collector	○	○
	Turret air blast	○	○
	Coolant temperature control	○	○
	High power coolant 1.1 kW (1.2 kW for cover)	●	●
	1.5 MPa (218 PSI) high pressure coolant 2.2 kW (50 Hz) / 3.0 kW (60 Hz) (1.2 kW for cover)	○	○
	SUPERFLOW coolant system	○	○
	Rear discharge chip conveyor (hinge)	○	○
	Rear discharge chip conveyor (ConSep2000WS)	○	○
Chip bucket	○	○	

## Machine Dimensions

Unit : mm (inch)

### MEGA TURN 500, 500M, 600, 600M

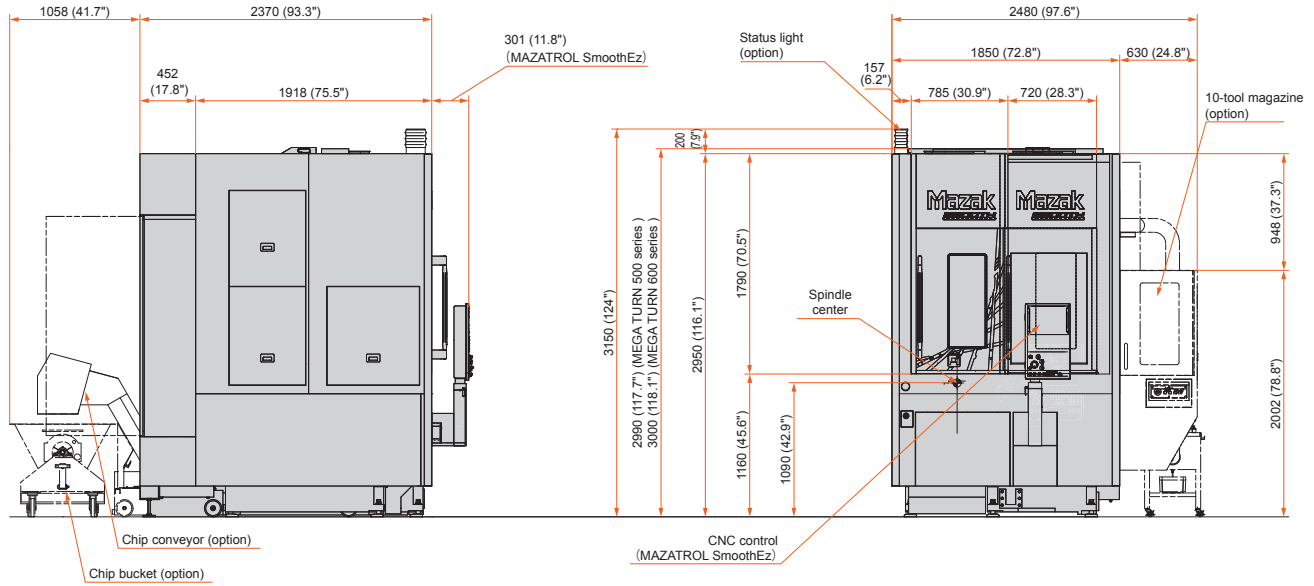

### MEGA TURN 500S, 500MS, 600S, 600MS

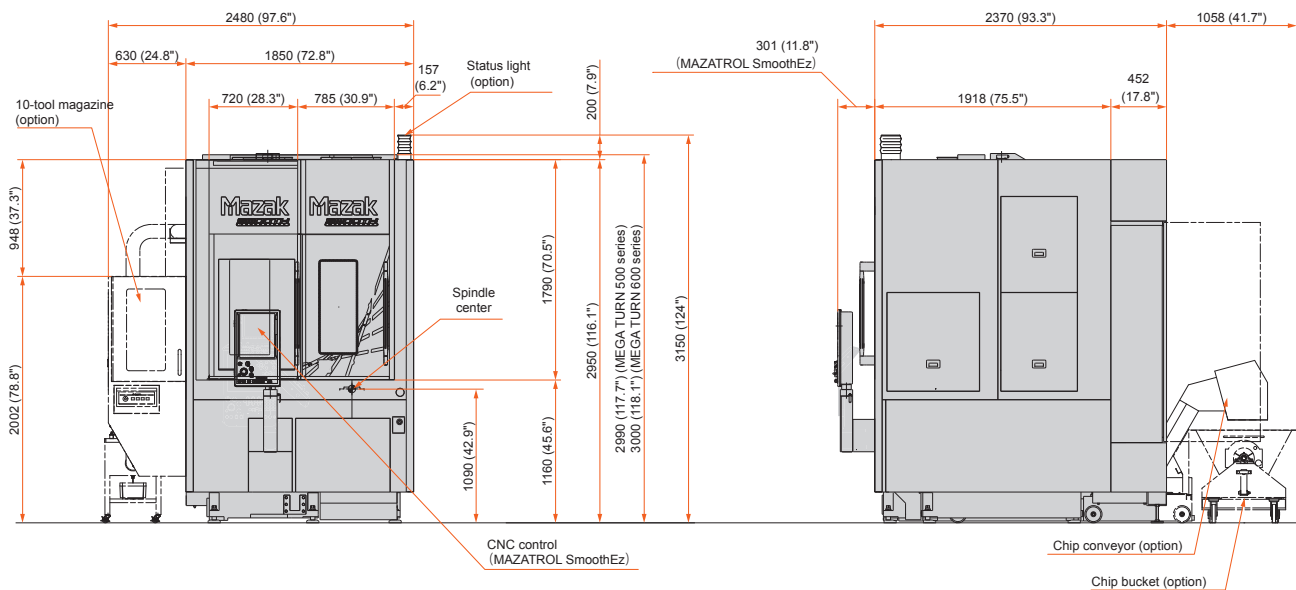

Unit : mm (inch)

MEGA TURN 900, 900M

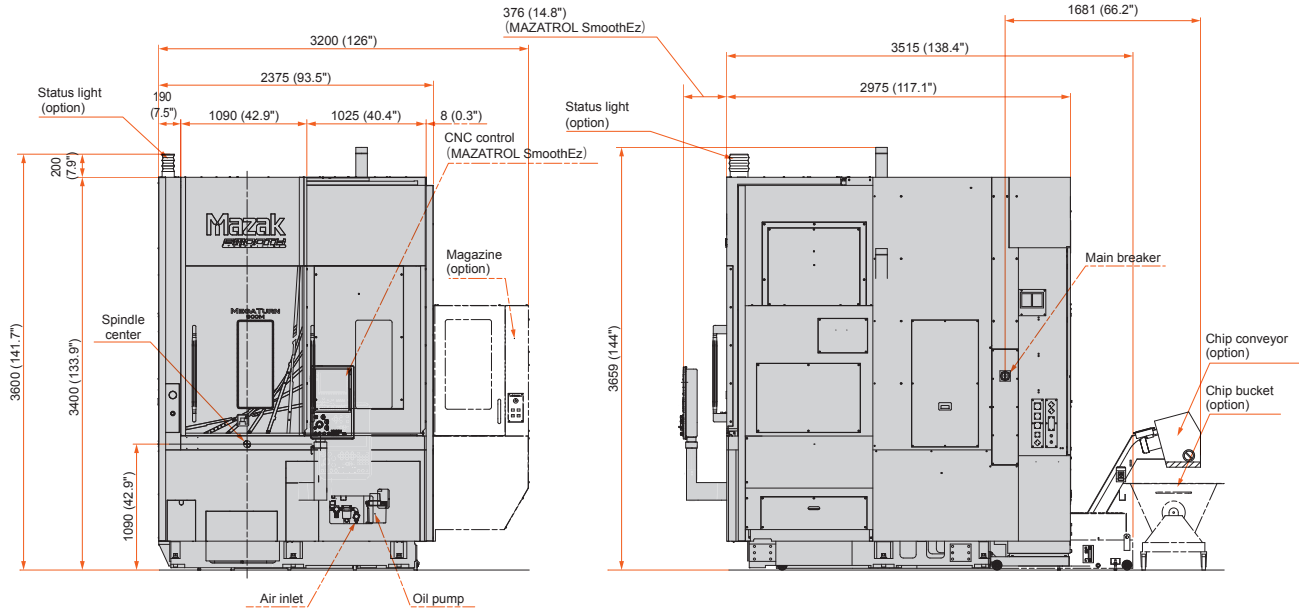

MEGA TURN 900S, 900MS

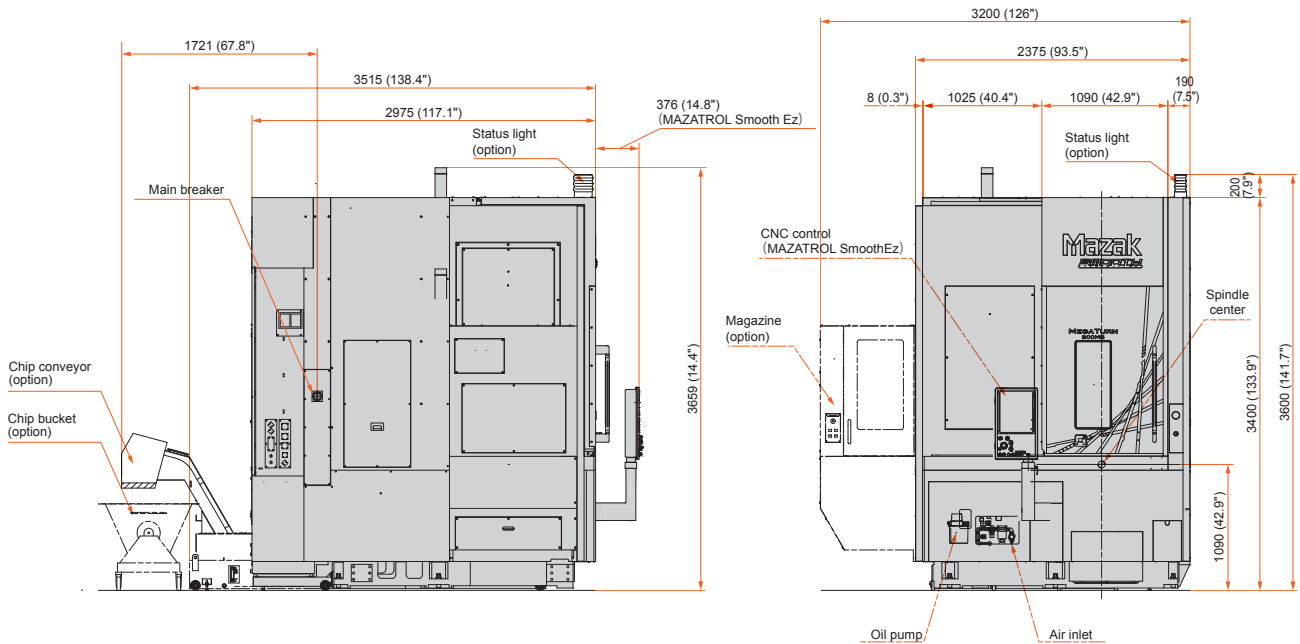

## Machine Dimensions

Unit: mm (inch)

### MEGA TURN 1600, 1600M

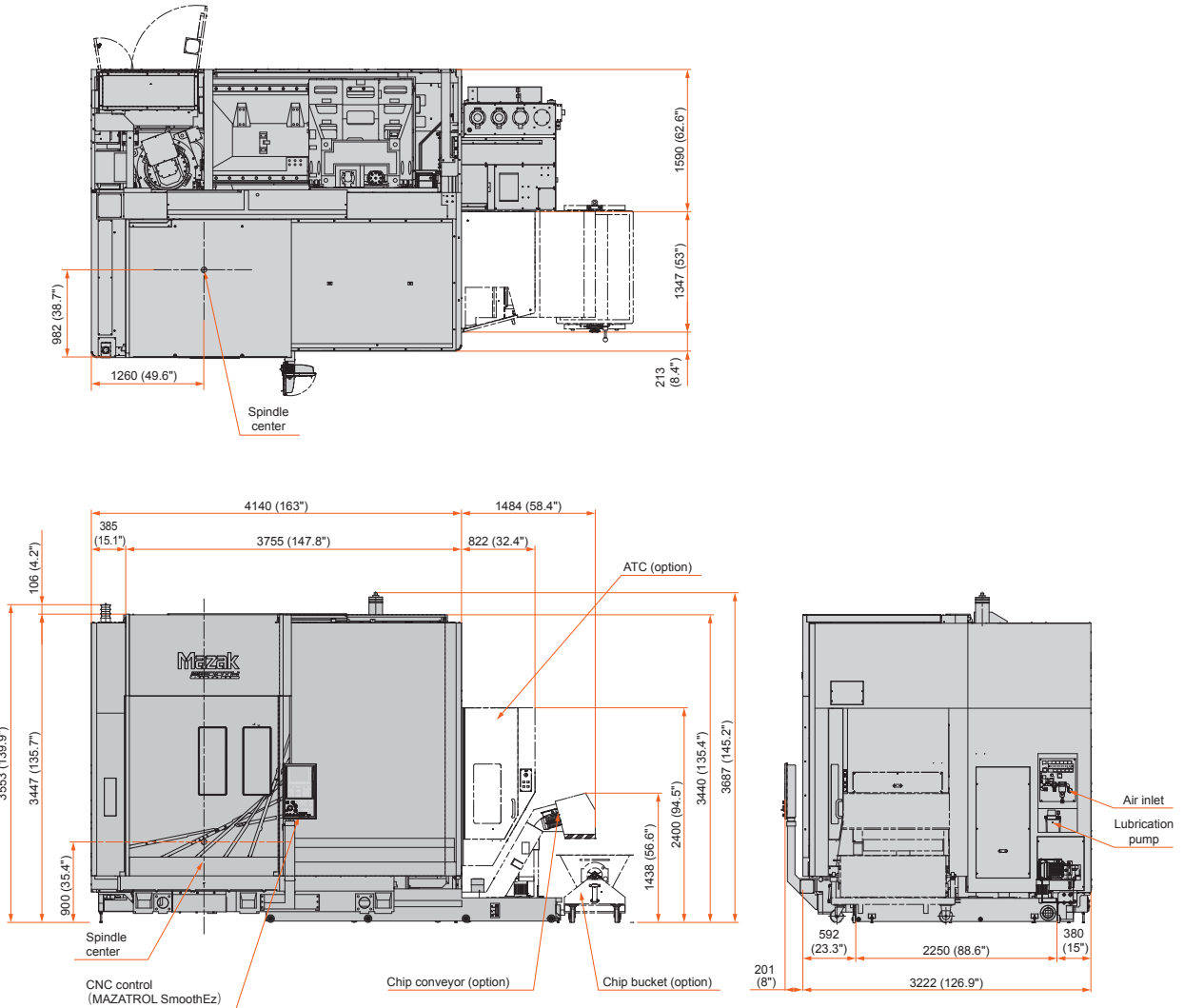

Chuck Dimensions

Unit: mm (inch)

**MEGA TURN 500**  
15" non-through hole NV-15

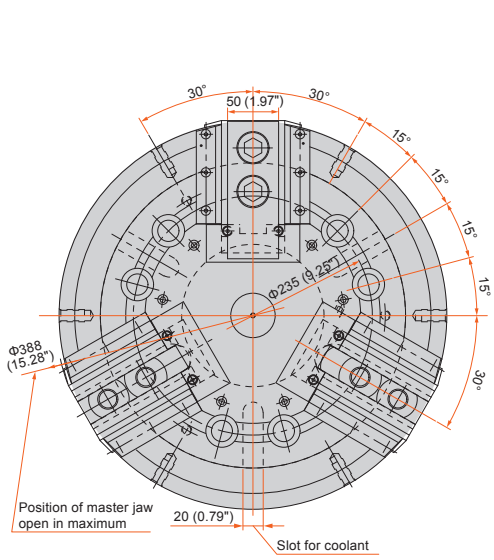

**MEGA TURN 500, 600**  
18" non-through hole NV-18

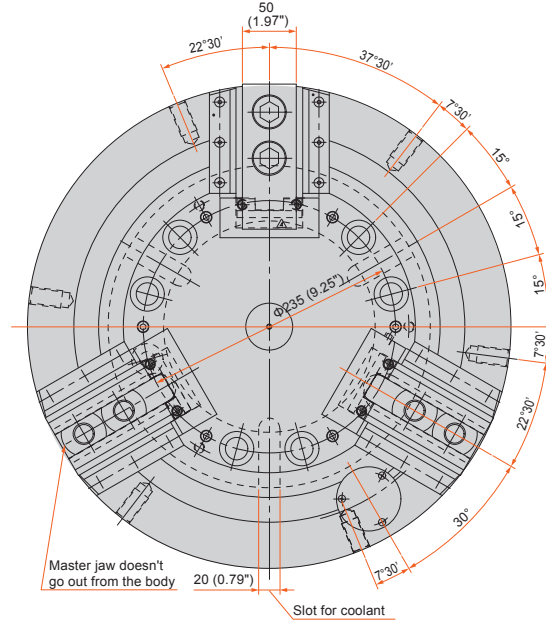

**MEGA TURN 900**  
36" non-through hole with 3-jaw chuck NV-36C1515

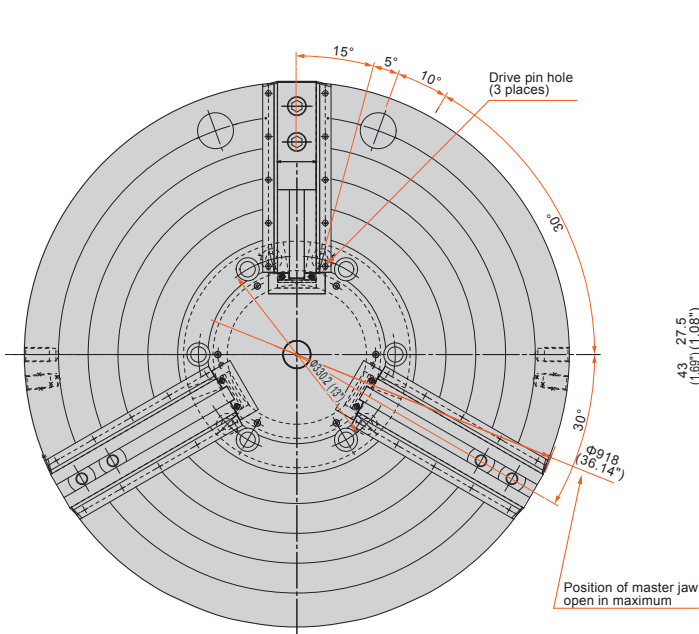

**MEGA TURN 1600**  
Φ1500 mm (Φ59.06") faceplate (including 4 jaws)

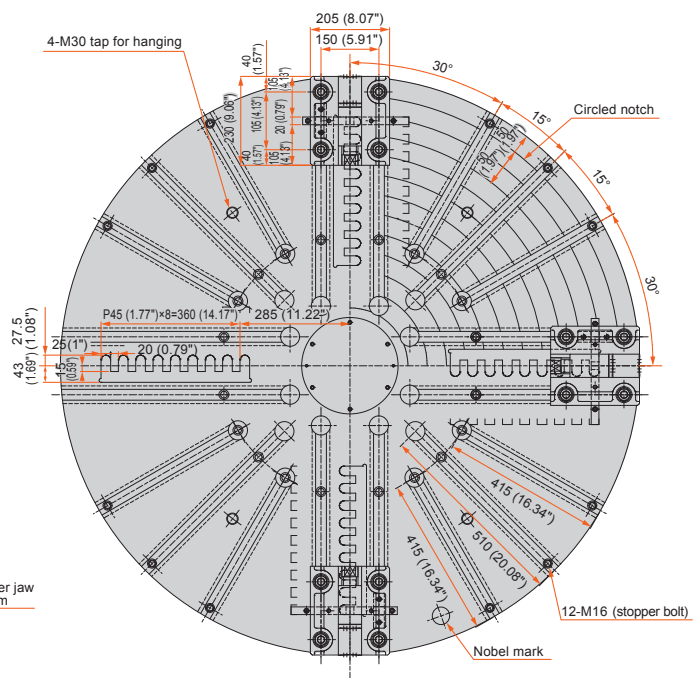

## MAZATROL SmoothEz Specifications

	MAZATROL	EIA
Number of controlled axes	Simultaneous 2 - 4 axes	
Least input increment	0.0001 mm, 0.00001 inch, 0.0001 deg	
High speed, high precision control	Shape error designation, Smooth corner control, Rapid traverse overlap	
Interpolation	Positioning (interpolation), Positioning (non-interpolation), Linear interpolation, Circular interpolation, Cylindrical interpolation, Polar coordinate interpolation, Constant lead threading, Re-threading*, Thread start point compensation*, Thread cut-speed override*, Synchronous tapping*	Positioning (interpolation), Positioning (non-interpolation), Linear interpolation, Circular interpolation, Spiral interpolation, Helical interpolation, Constant lead threading, Variable lead threading, Threading (C-axis interpolation type), Involute interpolation*, Cylindrical interpolation*, NURBS interpolation*, Polar coordinate interpolation*, Re-threading*, Thread start point compensation*, Thread cut-speed override*, Synchronous tapping
Feedrate	Rapid traverse, Cutting feed, Cutting feed (per minute), Cutting feed (per revolution), Dwell (time / rotation), Rapid traverse override, Cutting feed override, G0 speed variable control, Feedrate limitation, Variable acceleration control, G0 slope constant*	Rapid traverse, Cutting feed, Cutting feed (per minute), Cutting feed (per revolution), Inverse time feed, Dwell (time / rotation), Rapid traverse override, Cutting feed override, G0 speed variable control, Feedrate limitation, Time constant changing for G1, Variable acceleration control, G0 slope constant*
Program registration	Number of programs : 256 (Standard) / 960 (Max.), Program memory : 2 MB, Program memory expansion : 8 MB*, Program memory expansion : 32 MB*	
Control display	Display : 15" touch panel, Resolution : XGA	
Spindle functions	S code output, Spindle speed limitation, Spindle speed override, Spindle speed reaching detection, Multiple position orient, Constant surface speed, Spindle speed command with decimal digits, Synchronized spindle control, Spindle speed range setting	
Tool functions	Number of tool offset : 4000, T code output for tool number, Tool life monitoring (time), Tool life monitoring (number of machined workpieces), Tool life monitoring (wear)	Number of tool offset : 4000, T code output for tool number, T code output for group number, Tool life monitoring (time), Tool life monitoring (number of machined workpieces), Tool life monitoring (wear)
Miscellaneous functions	M code output, Simultaneous output of multiple M codes	
Tool offset functions	Tool position offset, Tool length offset, Tool diameter / tool nose R offset, Tool nose shape offset, Tool wear offset, Fixed amount offset, Simple wear offset	Tool position offset, Tool length offset, Tool diameter / tool nose R offset, Tool wear offset, Fixed amount offset, Simple wear offset
Coordinate system	Machine coordinate system, Work coordinate system, Local coordinate system, MAZATROL coordinate system, Additional work coordinates (300 sets)	
Machine functions	-	Polygon cutting*, Hobbing*
Machine compensation	Backlash compensation, Pitch error compensation, Thermal shield	
Protection functions	Emergency stop, Interlock, Pre-move stroke check, Barrier	
Automatic operation mode	Memory operation	Memory operation, Tape operation, MDI operation, SD card operation, EtherNet operation*
Automatic operation control	Optional stop, Dry run, Manual handle interruption, MDI interruption, TPS, Restart, Single process, Machine lock	Optional block skip, Optional stop, Dry run, Manual handle interruption, MDI interruption, TPS, Restart, Restart 2, Collation stop, Machine lock
Manual measuring functions	Tool-setting data teach, Tool length teach, Touch sensor coordinates measurement, Workpiece offset measurement, Tool eye measurement	Tool-setting data teach, Tool length teach, Tool offset teach, Touch sensor coordinates measurement, Workpiece offset measurement, Tool eye measurement
Automatic measuring functions	Workpiece measurement, Sensor calibration, Tool eye auto tool measurement	
Interface	PROFIBUS-DP*, EtherNet/IP*, CC-Link*	
Card interface	SD card interface, USB	
EtherNet	10 M / 100 M / 1 Gbps	

\*Option

# Mazak MPOWER

## SINGLE SOURCE SERVICE

Mazak is a single point of contact for any Mazak-related service need, whether it involves a machine, control, accessory or automation solution. This effective service approach helps customers maintain the highest possible levels of productivity.

## TECHNICAL SUPPORT

Comprehensive two-year warranties on every Mazak machine tool, paired with local support from a network of Technology and Technical Centers and expert technical service through the company's Remote Assist Services.

## PARTS SUPPORT

Identify, order and receive the replacements you need with unprecedented speed and ease through online access to every aspect of parts support. Whether you need a small part or a CNC repair, you're covered 24/7.

## TRAINING

Learn to operate, program and maintain your Mazak machine tools so you obtain the full value of your equipment, from installation throughout its working life. Take a self-paced course through our MPower On-Demand Learning (MODL) system, schedule an in-person class at one of our Technology or Technical Centers, or sign up for a customized seminar in your shop.

## SPINDLE AND UNIT REBUILD

Mazak's cost-effective Spindle Rebuilding Services offer customers fast and precise spindle rebuilding under the MPower umbrella. The Mazak Spindle Rebuild Department raises the bar in terms of efficiency and quality in OEM-factory-certified machine tool spindle rebuild services that significantly reduce customer downtime.

## Technical and Technology Centers

### National Technology Center

Florence, Kentucky  
1-800-331-9151

### Northeast Technology Center

Windsor Locks, Connecticut 06096  
(860) 292-4400

### Southeast Technology Center

Suwanee, Georgia 30024  
(678) 985-4800

### Florida Technical Center

Orlando, FL 32822  
(689) 205-5626

### Midwest Technology Center

Schaumburg, Illinois 60173  
(847) 885-8311

### Southwest Technology Center

Houston, Texas 77067  
(281) 931-7770

### Dallas Technical Center

Southlake, Texas 76092  
(817) 329-6290

### Western Technology Center

Gardena, California 90248  
(310) 327-7172

### Northern California Technical Center

Fremont, California 94538  
(408) 941-2240

### Mazak MegaStir

Provo, Utah 84606  
(385) 219-4614

### Canada Technology Centre

Cambridge, Ontario N3C 4P7  
(519) 658-2021

### Mexico Technology Center

Apodaca Nuevo Leon 66600  
011-52-818-221-0910

### Edmonton Technical Centre

Edmonton, Alberta T6B 3T5  
(587) 404-8199



**MAZAK CORPORATION  
NORTH AMERICAN MANUFACTURING  
HEADQUARTERS**

8025 Production Drive, Florence, KY 41042  
Tel: (859) 342-1700 Fax: (859) 342-1865

[www.mazakUSA.com](http://www.mazakUSA.com)

- Specifications are subject to change without notice.
- This product is subject to all applicable export control laws and regulations.
- The accuracy data and other data presented in this catalogue were obtained under specific conditions. They may not be duplicated under different conditions. (room temperature, workpiece materials, tool material, cutting conditions, etc.)
- Unauthorized copying of this catalogue is prohibited.



MEGA TURN SERIES 23.07.17 0 G 99J1B1722E0